

Needle Valves



ROKE
Valves ,Fittings and Tubing

www.chinaroke.com

Contents

Integral Bonnet Needle Valves

BN and BNH Series (3000/5000 psig) 01

Nonrotating-stem Needle Valves

NSV and NSH Series (3000PSI/5000PSI) 06

Integral Bar Stock Needle Valves

BFN Series (6000 psig) 09

Bar Stock Needle Valves

BSN Series (6000 psig) 12

Forged Needle Valves

FNH Series (10000 psig) 15

Union Bonnet Needle Valves

UBN and UBNH Series (6000/10000 psig) 18

Rising Plug Valves

RP and RPG Series (6000 psig) 22

Gauge Valves

GVB and GVR Series (6000 psig) 24

Bleed Valves

BDV Series (10000PSI) 26

Part NO. Description

For Example: **SS-BN-MN 2-FN 2-3-11c-A**

Material	Series	Inlet or Outlet	Size	Orifice	Stem	Type
SS: SS 316	BN: BN Series	FN: Female Npt	2: 1/8"	3: 3mm	11a	A: Angle
S9: SS 904L	BNH: BNH Series	MN: Male Npt	3: 3/16" or 3mm	4: 4mm	11b	3W: 3-way
S4: SS 304	FN: FN Series	FR: Female BSPT	4: 1/4"	5: 5.1mm	11c	
S2: SS 321	FNH: FNH Series	MR: Male BSPT	5: 5/16"	6: 6.4mm		
M4: Monle 400	UBN: UBN Series	FT: Fractional Tube	6: 3/8" or 6mm	7: 7.5mm		
I6: Inconle 625	UBNH: UBNH Series	MT: Metric Tube	8: 1/2" or 8mm	9: 9.1mm		
HC: Hastelly C 276	RPN: RPH Series	BW: Butt Weld	10: 5/8" or 10mm	12: 12.2mm		
B: Brass		SW: Socket Weld	12: 3/4" or 12mm	15: 15mm		
CS: Cabon Steel			16: 1" or 16mm			

Integral Bonnet Needle Valves

BN Series: Maximum working pressure 3000 psig

BNH Series: Maximum working pressure 5000 psig

Features

- ⦿ One-piece forged body.
- ⦿ Easy external adjustments by packing nut.
- ⦿ Compact design.
- ⦿ Handle of different colors available for option.
- ⦿ Leak-tight performance testing for every valve at the maximum working pressure with nitrogen.
- ⦿ Maximum working pressure:
 - BN Series (Soft sealing): 3000 psig (207 bar)
 - BNH Series (Hard sealing): 5000 psig (345 bar)
- ⦿ Working temperature:
 - PTFE: -65°F to 450°F (-54°C to 232°C)
 - PEEK: -65°F to 500°F (-54°C to 260°C)



Standard Materials of Construction

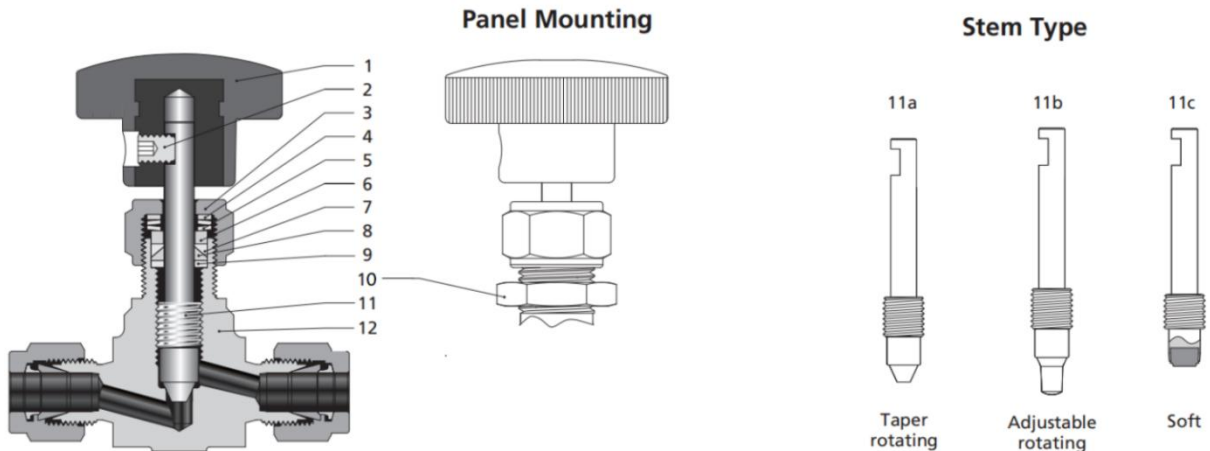

NO.	Component	Material		
		316 SS	Brass	Alloy 400
1	Handle	Anodized aluminum or stainless steel or black knob		
2	Set Screw	Stainless steel		
3	Packing Bolt	316 SS/A276	Brass 36000/B16	Alloy 400/B164
4	Washer	316 SS/A276		
5	Packing Spring	S17700/A693		
6	Washer	316 SS/A276		
7	Upper Packing	PTFE/PEEK		
8	Lower Packing	PTFE/PEEK		
9	Packing Washer	316 SS/A276		
10	Panel Nut	316 SS/A276		
11	Stem	316 SS/A276	304 SS/A276	Alloy 400/B164
12	Body	316 SS/A182	Brass 36000/B16	Alloy 400/B164

- ⦿ Note: The BN/BNH series needle valves default to panel installation structure when leaving the factory.

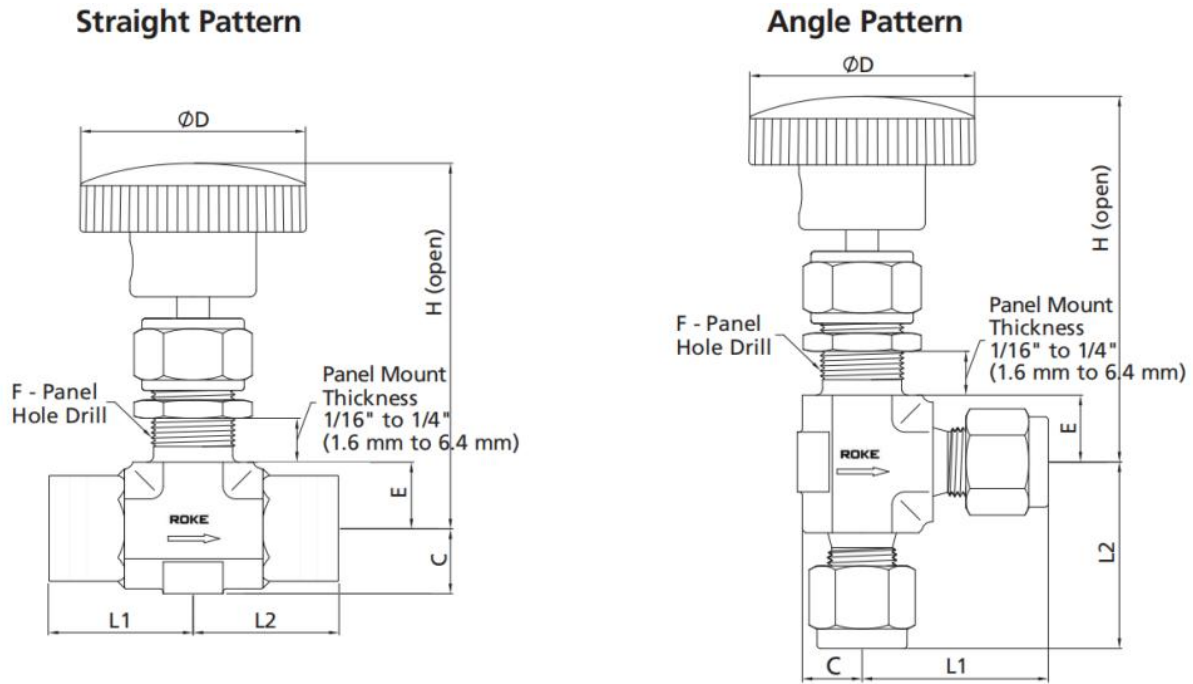

Dimensions of BN Series (Soft sealing, 3000 psig)

Basic Ordering Number	Connection Type and Size		Orifice in.(mm)	Cv	Dimension, in.(mm)						
	Inlet	Outlet			L1	L2	C	D	E	F	H
-BN-FN2-2	1/8 Female NPT	1/8 Female NPT	0.08 (2.0)	0.09	0.81 (20.6)	0.81 (20.6)	0.32 (8.1)	1.38 (35.0)	0.44 (11.2)	0.47 (11.9)	2.28 (58.0)
-BN-FN4-4	1/4 Female NPT	1/4 Female NPT	0.16 (4.0)	0.35	0.98 (25.0)	0.98 (25.0)	0.39 (10.0)	1.38 (35.0)	0.44 (11.2)	0.53 (13.5)	2.50 (63.5)
-BN-FN4-6	1/4 Female NPT	1/4 Female NPT	0.25 (6.4)	0.70	1.06 (27.0)	1.06 (27.0)	0.50 (12.7)	1.88 (47.8)	0.50 (12.7)	0.78 (19.8)	2.97 (75.5)
-BN-FN6-6	3/8 Female NPT	3/8 Female NPT	0.25 (6.4)	0.70	1.06 (27.0)	1.06 (27.0)	0.50 (12.7)	1.88 (47.8)	0.50 (12.7)	0.78 (19.8)	2.97 (75.5)
-BN-FN8-10	1/2 Female NPT	1/2 Female NPT	0.39 (10.0)	1.80	1.50 (38.1)	1.50 (38.1)	0.75 (19.1)	3.50 (88.9)	0.75 (19.1)	1.03 (26.2)	3.91 (93.3)
-BN-MN2-2	1/8 Male NPT	1/8 Male NPT	0.08 (2.0)	0.09	0.81 (20.6)	0.81 (20.6)	0.32 (8.1)	1.38 (35.0)	0.44 (11.2)	0.47 (11.9)	2.28 (58.0)
-BN-MN4-4	1/4 Male NPT	1/4 Male NPT	0.16 (4.0)	0.35	0.98 (25.0)	0.98 (25.0)	0.39 (10.0)	1.38 (35.0)	0.44 (11.2)	0.53 (13.5)	2.50 (63.5)
-BN-MN6-6	3/8 Male NPT	3/8 Male NPT	0.25 (6.4)	0.70	1.12 (28.4)	1.12 (28.4)	0.50 (12.7)	1.88 (47.8)	0.50 (12.7)	0.78 (19.8)	2.97 (75.5)
-BN-MN8-6	1/2 Male NPT	1/2 Male NPT	0.25 (6.4)	0.70	1.50 (38.1)	1.50 (38.1)	0.50 (12.7)	1.88 (47.8)	0.50 (12.7)	0.78 (19.8)	2.97 (75.5)
-BN-MN12-10	3/4 Male NPT	3/4 Male NPT	0.39 (10.0)	1.80	1.63 (41.3)	1.63 (41.3)	0.75 (19.1)	3.50 (88.9)	0.75 (19.1)	1.03 (26.2)	3.92 (99.6)
-BN-FT2-2	1/8" Tube	1/8" Tube	0.08 (2.0)	0.09	0.98 (25.0)	0.98 (25.0)	0.32 (8.1)	1.38 (35.0)	0.44 (11.2)	0.47 (11.9)	2.28 (58.0)
-BN-FT4-4	1/4" Tube	1/4" Tube	0.16 (4.0)	0.35	1.12 (28.4)	1.12 (28.4)	0.39 (10.0)	1.38 (35.0)	0.44 (11.2)	0.53 (13.5)	2.50 (63.5)
-BN-FT6-6	3/8" Tube	3/8" Tube	0.25 (6.4)	0.70	1.29 (32.8)	1.29 (32.8)	0.50 (12.7)	1.88 (47.8)	0.50 (12.7)	0.78 (19.8)	2.97 (75.5)
-BN-FT8-6	1/2" Tube	1/2" Tube	0.25 (6.4)	0.70	1.40 (35.6)	1.40 (35.6)	0.50 (12.7)	1.88 (47.8)	0.50 (12.7)	0.78 (19.8)	2.97 (75.5)
-BN-FT8-10	1/2" Tube	1/2" Tube	0.39 (10.0)	1.80	1.90 (48.3)	1.90 (48.3)	0.75 (19.1)	3.50 (88.9)	0.75 (19.1)	1.03 (26.2)	3.92 (99.6)
-BN-FT12-10	3/4" Tube	3/4" Tube	0.39 (10.0)	1.80	1.90 (48.3)	1.90 (48.3)	0.75 (19.1)	3.50 (88.9)	0.75 (19.1)	1.03 (26.2)	3.92 (99.6)
-BN-MT3-2	3 mm	3 mm	0.08 (2.0)	0.09	0.98 (25.0)	0.98 (25.0)	0.32 (8.1)	1.38 (35.0)	0.44 (11.2)	0.47 (11.9)	2.28 (58.0)
-BN-MT6-4	6 mm	6 mm	0.16 (4.0)	0.35	1.12 (28.4)	1.12 (28.4)	0.39 (10.0)	1.38 (35.0)	0.44 (11.2)	0.53 (13.5)	2.50 (63.5)
-BN-MT8-4	8 mm	8 mm	0.16 (4.0)	0.35	1.17 (29.6)	1.17 (29.6)	0.39 (10.0)	1.38 (35.0)	0.44 (11.2)	0.53 (13.5)	2.50 (63.5)
-BN-MT10-6	10 mm	10 mm	0.25 (6.4)	0.70	1.29 (32.8)	1.29 (32.8)	0.50 (12.7)	1.88 (47.8)	0.50 (12.7)	0.78 (19.8)	2.97 (75.5)
-BN-MT12-6	12 mm	12 mm	0.25 (6.4)	0.70	1.40 (35.6)	1.40 (35.6)	0.50 (12.7)	1.88 (47.8)	0.50 (12.7)	0.78 (19.8)	2.97 (75.5)
-BN-MT14-6	14 mm	14 mm	0.25 (6.4)	0.70	1.56 (39.7)	1.56 (39.7)	0.50 (12.7)	1.88 (47.8)	0.50 (12.7)	0.78 (19.8)	2.97 (75.5)
-BN-MT18-16	16 mm	16 mm	0.39 (10.0)	1.80	1.90 (48.3)	1.90 (48.3)	0.75 (19.1)	3.50 (88.9)	0.75 (19.1)	1.03 (26.2)	3.92 (99.6)
-BN-MT18-10	18 mm	18 mm	0.39 (10.0)	1.80	1.90 (48.3)	1.90 (48.3)	0.75 (19.1)	3.50 (88.9)	0.75 (19.1)	1.03 (26.2)	3.92 (99.6)

Dimensions of BNH Series (Hard sealing, 5000 psig)

Basic Ordering Number	Connection Type and Size		Orifice in(mm)	Cv	Dimension, in.(mm)						
	Inlet	Outlet			L1	L2	C	D	E	F	H
-BNH-FN2-2	1/8 Female NPT	1/8 Female NPT	0.08 (2.0)	0.09	0.81 (20.6)	0.81 (20.6)	0.32 (8.1)	1.38 (35.0)	0.44 (11.2)	0.47 (11.9)	2.28 (58.0)
-BNH-FN4-4	1/4 Female NPT	1/4 Female NPT	0.16 (4.0)	0.35	0.98 (25.0)	0.98 (25.0)	0.39 (10.0)	1.38 (35.0)	0.44 (11.2)	0.53 (13.5)	2.50 (63.5)
-BNH-FN4-6	1/4 Female NPT	1/4 Female NPT	0.25 (6.4)	0.70	1.06 (27.0)	1.06 (27.0)	0.50 (12.7)	1.88 (47.8)	0.50 (12.7)	0.78 (19.8)	2.97 (75.5)
-BNH-FN6-6	3/8 Female NPT	3/8 Female NPT	0.25 (6.4)	0.70	1.06 (27.0)	1.06 (27.0)	0.50 (12.7)	1.88 (47.8)	0.50 (12.7)	0.78 (19.8)	2.97 (75.5)
-BNH-FN8-10	1/2 Female NPT	1/2 Female NPT	0.39 (10.0)	1.80	1.50 (38.1)	1.50 (38.1)	0.75 (19.1)	3.50 (88.9)	0.75 (19.1)	1.03 (26.2)	3.91 (93.3)
-BNH-MN2-2	1/8 Male NPT	1/8 Male NPT	0.08 (2.0)	0.09	0.81 (20.6)	0.81 (20.6)	0.32 (8.1)	1.38 (35.0)	0.44 (11.2)	0.47 (11.9)	2.28 (58.0)
-BNH-MN4-4	1/4 Male NPT	1/4 Male NPT	0.16 (4.0)	0.35	0.98 (25.0)	0.98 (25.0)	0.39 (10.0)	1.38 (35.0)	0.44 (11.2)	0.53 (13.5)	2.50 (63.5)
-BNH-MN6-6	3/8 Male NPT	3/8 Male NPT	0.25 (6.4)	0.70	1.12 (28.4)	1.12 (28.4)	0.50 (12.7)	1.88 (47.8)	0.50 (12.7)	0.78 (19.8)	2.97 (75.5)
-BNH-MN8-6	1/2 Male NPT	1/2 Male NPT	0.25 (6.4)	0.70	1.50 (38.1)	1.50 (38.1)	0.50 (12.7)	1.88 (47.8)	0.50 (12.7)	0.78 (19.8)	2.97 (75.5)
-BNH-MN12-10	3/4 Male NPT	3/4 Male NPT	0.39 (10.0)	1.80	1.63 (41.3)	1.63 (41.3)	0.75 (19.1)	3.50 (88.9)	0.75 (19.1)	1.03 (26.2)	3.92 (99.6)
-BNH-FT2-2	1/8" Tube	1/8" Tube	0.08 (2.0)	0.09	0.98 (25.0)	0.98 (25.0)	0.32 (8.1)	1.38 (35.0)	0.44 (11.2)	0.47 (11.9)	2.28 (58.0)
-BNH-FT4-4	1/4" Tube	1/4" Tube	0.16 (4.0)	0.35	1.12 (28.4)	1.12 (28.4)	0.39 (10.0)	1.38 (35.0)	0.44 (11.2)	0.53 (13.5)	2.50 (63.5)
-BNH-FT6-6	3/8" Tube	3/8" Tube	0.25 (6.4)	0.70	1.29 (32.8)	1.29 (32.8)	0.50 (12.7)	1.88 (47.8)	0.50 (12.7)	0.78 (19.8)	2.97 (75.5)
-BNH-FT8-6	1/2" Tube	1/2" Tube	0.25 (6.4)	0.70	1.40 (35.6)	1.40 (35.6)	0.50 (12.7)	1.88 (47.8)	0.50 (12.7)	0.78 (19.8)	2.97 (75.5)
-BNH-FT8-10	1/2" Tube	1/2" Tube	0.39 (10.0)	1.80	1.90 (48.3)	1.90 (48.3)	0.75 (19.1)	3.00 (76.2)	0.75 (19.1)	1.03 (26.2)	3.92 (99.6)
-BNH-FT12-10	3/4" Tube	3/4" Tube	0.39 (10.0)	1.80	1.90 (48.3)	1.90 (48.3)	0.75 (19.1)	3.00 (76.2)	0.75 (19.1)	1.03 (26.2)	3.92 (99.6)
-BNH-MT3-2	3 mm	3 mm	0.08 (2.0)	0.09	0.98 (25.0)	0.98 (25.0)	0.32 (8.1)	1.38 (35.0)	0.44 (11.2)	0.47 (11.9)	2.28 (58.0)
-BNH-MT6-4	6 mm	6 mm	0.16 (4.0)	0.35	1.12 (28.4)	1.12 (28.4)	0.39 (10.0)	1.38 (35.0)	0.44 (11.2)	0.53 (13.5)	2.50 (63.5)
-BNH-MT8-4	8 mm	8 mm	0.16 (4.0)	0.35	1.17 (29.6)	1.17 (29.6)	0.39 (10.0)	1.38 (35.0)	0.44 (11.2)	0.53 (13.5)	2.50 (63.5)
-BNH-MT10-6	10 mm	10 mm	0.25 (6.4)	0.70	1.29 (32.8)	1.29 (32.8)	0.50 (12.7)	1.88 (47.8)	0.50 (12.7)	0.78 (19.8)	2.97 (75.5)
-BNH-MT12-6	12 mm	12 mm	0.25 (6.4)	0.70	1.40 (35.6)	1.40 (35.6)	0.50 (12.7)	1.88 (47.8)	0.50 (12.7)	0.78 (19.8)	2.97 (75.5)
-BNH-MT14-6	14 mm	14 mm	0.25 (6.4)	0.70	1.56 (39.7)	1.56 (39.7)	0.50 (12.7)	1.88 (47.8)	0.50 (12.7)	0.78 (19.8)	2.97 (75.5)
-BNH-MT16-10	16 mm	16 mm	0.39 (10.0)	1.80	1.90 (48.3)	1.90 (48.3)	0.75 (19.1)	3.50 (88.9)	0.75 (19.1)	1.03 (26.2)	3.92 (99.6)
-BNH-MT18-10	18 mm	18 mm	0.39 (10.0)	1.80	1.90 (48.3)	1.90 (48.3)	0.75 (19.1)	3.50 (88.9)	0.75 (19.1)	1.03 (26.2)	3.92 (99.6)

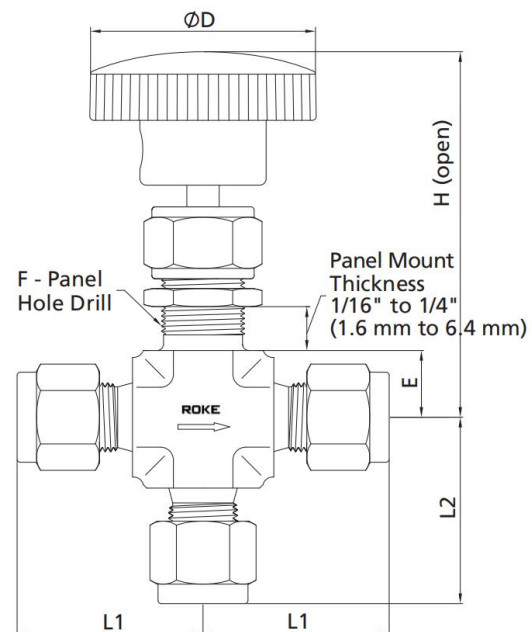
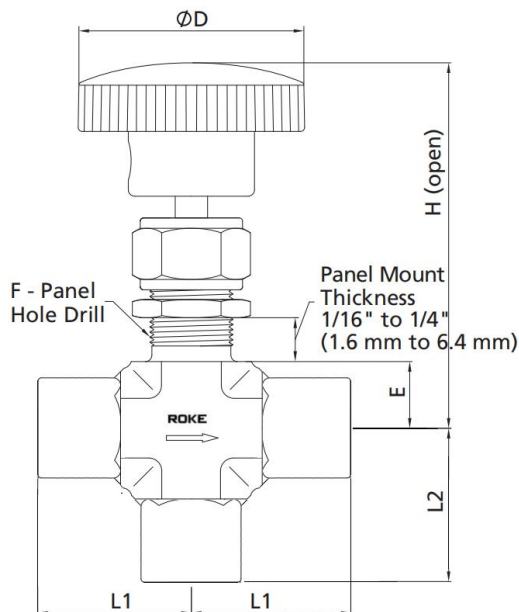

Dimensions of BN 3-Way Series (Soft sealing, 3000 psig)

Basic Ordering Number	Connection Type and Size		Orifice in.(mm)	Cv	Dimension, in.(mm)					
	Inlet	Outlet			L1	L2	D	E	F	H
	-BN-FN2-2-3W	1/8 Female NPT			1/8 Female NPT	0.08 (2.0)	0.09	0.81 (20.6)	0.81 (20.6)	1.38 (35.0)
-BN-FN4-4-3W	1/4 Female NPT	1/4 Female NPT	0.16 (4.0)	0.35	0.98 (25.0)	0.98 (25.0)	1.38 (35.0)	0.44 (11.2)	0.53 (13.5)	2.50 (63.5)
-BN-FN4-6-3W	1/4 Female NPT	1/4 Female NPT	0.25 (6.4)	0.70	1.06 (27.0)	1.06 (27.0)	1.88 (47.8)	0.50 (12.7)	0.78 (19.8)	2.97 (75.5)
-BN-FN6-6-3W	3/8 Female NPT	3/8 Female NPT	0.25 (6.4)	0.70	1.06 (27.0)	1.06 (27.0)	1.88 (47.8)	0.50 (12.7)	0.78 (19.8)	2.97 (75.5)
-BN-FN8-6-3W	1/2 Female NPT	1/2 Female NPT	0.39 (10.0)	1.80	1.50 (38.1)	1.50 (38.1)	3.50 (88.9)	0.75 (19.1)	1.03 (26.2)	3.91 (99.3)
-BN-MN2-2-3W	1/8 Male NPT	1/8 Male NPT	0.08 (2.0)	0.09	0.81 (20.6)	0.81 (20.6)	1.38 (35.0)	0.44 (11.2)	0.47 (11.9)	2.28 (58.0)
-BN-MN4-4-3W	1/4 Male NPT	1/4 Male NPT	0.16 (4.0)	0.35	0.98 (25.0)	0.98 (25.0)	1.38 (35.0)	0.44 (11.2)	0.53 (13.5)	2.50 (63.5)
-BN-MN6-6-3W	3/8 Male NPT	3/8 Male NPT	0.25 (6.4)	0.70	1.12 (28.4)	1.12 (28.4)	1.88 (47.8)	0.50 (12.7)	0.78 (19.8)	2.97 (75.5)
-BN-MN8-6-3W	1/2 Male NPT	1/2 Male NPT	0.25 (6.4)	0.70	1.50 (38.1)	1.50 (38.1)	1.88 (47.8)	0.50 (12.7)	0.78 (19.8)	2.97 (75.5)
-BN-MN12-10-3W	3/4 Male NPT	3/4 Male NPT	0.39 (10.0)	1.80	1.63 (41.3)	1.63 (41.3)	3.50 (88.9)	0.75 (19.1)	1.03 (26.2)	3.92 (99.6)
-BN-FT2-2-3W	1/8" Tube	1/8" Tube	0.08 (2.0)	0.09	0.98 (25.0)	0.98 (25.0)	1.38 (35.0)	0.44 (11.2)	0.53 (13.5)	2.28 (58.0)
-BN-FT4-4-3W	1/4" Tube	1/4" Tube	0.16 (4.0)	0.35	1.12 (28.4)	1.12 (28.4)	1.38 (35.0)	0.44 (11.2)	0.55 (13.9)	2.50 (63.5)
-BN-FT6-6-3W	3/8" Tube	3/8" Tube	0.25 (6.4)	0.70	1.29 (32.8)	1.29 (32.8)	1.88 (47.8)	0.50 (12.7)	0.55 (13.9)	2.97 (75.5)
-BN-FT8-6-3W	1/2" Tube	1/2" Tube	0.25 (6.4)	0.70	1.40 (35.6)	1.40 (35.6)	1.88 (47.8)	0.50 (12.7)	0.78 (19.8)	2.97 (75.5)
-BN-FT8-10-3W	1/2" Tube	1/2" Tube	0.39 (10.0)	1.80	1.90 (48.3)	1.90 (48.3)	3.50 (88.9)	0.75 (19.1)	1.03 (26.2)	3.92 (99.6)
-BN-FT12-10-3W	3/4" Tube	3/4" Tube	0.39 (10.0)	1.80	1.90 (48.3)	1.90 (48.3)	3.50 (88.9)	0.75 (19.1)	1.03 (26.2)	3.92 (99.6)
-BN-MT3-2-3W	3 mm	3 mm	0.08 (2.0)	0.09	0.98 (25.0)	0.98 (25.0)	1.38 (35.0)	0.44 (11.2)	0.47 (11.9)	2.28 (58.0)
-BN-MT6-4-3W	6 mm	6 mm	0.16 (4.0)	0.35	1.12 (28.4)	1.12 (28.4)	1.38 (35.0)	0.44 (11.2)	0.53 (13.5)	2.50 (63.5)
-BN-MT8-4-3W	8 mm	8 mm	0.16 (4.0)	0.35	1.17 (29.6)	1.17 (29.6)	1.38 (35.0)	0.44 (11.2)	0.53 (13.5)	2.50 (63.5)
-BN-MT10-6-3W	10 mm	10 mm	0.25 (6.4)	0.70	1.29 (32.8)	1.29 (32.8)	1.88 (47.8)	0.50 (12.7)	0.78 (19.8)	2.97 (75.5)
-BN-MT12-6-3W	12 mm	12 mm	0.25 (6.4)	0.70	1.40 (35.6)	1.40 (35.6)	1.88 (47.8)	0.50 (12.7)	0.78 (19.8)	2.97 (75.5)
-BN-MT14-6-3W	14 mm	14 mm	0.25 (6.4)	0.70	1.56 (39.7)	1.56 (39.7)	1.88 (47.8)	0.50 (12.7)	0.78 (19.8)	2.97 (75.5)
-BN-MT16-10-3W	16 mm	16 mm	0.39 (10.0)	1.80	1.90 (48.3)	1.90 (48.3)	3.50 (88.9)	0.75 (19.1)	1.03 (26.2)	3.92 (99.6)
-BN-MT18-10-3W	18 mm	18 mm	0.39 (10.0)	1.80	1.90 (48.3)	1.90 (48.3)	3.50 (88.9)	0.75 (19.1)	1.03 (26.2)	3.92 (99.6)

Dimensions of BNH 3-Way Series (Hard sealing, 5000 psig)

Basic Ordering Number	Connection Type and Size		Orifice in.(mm)	Cv	Dimension, in.(mm)					
	Inlet	Outlet			L1	L2	D	E	F	H
	-BN-FN2-2-3W	1/8 Female NPT			1/8 Female NPT	0.08 (2.0)	0.09	0.81 (20.6)	0.81 (20.6)	1.38 (35.0)
-BN-FN4-4-3W	1/4 Female NPT	1/4 Female NPT	0.16 (4.0)	0.35	0.98 (25.0)	0.98 (25.0)	1.38 (35.0)	0.44 (11.2)	0.53 (13.5)	2.50 (63.5)
-BN-FN4-6-3W	1/4 Female NPT	1/4 Female NPT	0.25 (6.4)	0.70	1.06 (27.0)	1.06 (27.0)	1.88 (47.8)	0.50 (12.7)	0.78 (19.8)	2.97 (75.5)
-BN-FN6-6-3W	3/8 Female NPT	3/8 Female NPT	0.25 (6.4)	0.70	1.06 (27.0)	1.06 (27.0)	1.88 (47.8)	0.50 (12.7)	0.78 (19.8)	2.97 (75.5)
-BN-FN8-6-3W	1/2 Female NPT	1/2 Female NPT	0.39 (10.0)	1.80	1.50 (38.1)	1.50 (38.1)	1.88 (47.8)	0.75 (19.1)	1.03 (26.2)	3.91 (99.3)
-BN-MN2-2-3W	1/8 Male NPT	1/8 Male NPT	0.08 (2.0)	0.09	0.81 (20.6)	0.81 (20.6)	1.38 (35.0)	0.44 (11.2)	0.47 (11.9)	2.28 (58.0)
-BN-MN4-4-3W	1/4 Male NPT	1/4 Male NPT	0.16 (4.0)	0.35	0.98 (25.0)	0.98 (25.0)	1.38 (35.0)	0.44 (11.2)	0.53 (13.5)	2.50 (63.5)
-BN-MN6-6-3W	3/8 Male NPT	3/8 Male NPT	0.25 (6.4)	0.70	1.12 (28.4)	1.12 (28.4)	1.88 (47.8)	0.50 (12.7)	0.78 (19.8)	2.97 (75.5)
-BN-MN8-6-3W	1/2 Male NPT	1/2 Male NPT	0.25 (6.4)	0.70	1.50 (38.1)	1.50 (38.1)	1.88 (47.8)	0.50 (12.7)	0.78 (19.8)	2.97 (75.5)
-BN-MN12-10-3W	3/4 Male NPT	3/4 Male NPT	0.39 (10.0)	1.80	1.63 (41.3)	1.63 (41.3)	3.00 (76.2)	0.75 (19.1)	1.03 (26.2)	3.92 (99.6)

Basic Ordering Number	Connection Type and Size		Orifice in(mm)	Cv	Dimension, in.(mm)					
	Inlet	Outlet			L1	L2	D	E	F	H
-BNH-FT2-2-3W	1/8" Tube	1/8" Tube	0.08 (2.0)	0.09	0.98 (25.0)	0.98 (25.0)	1.38 (35.0)	0.44 (11.2)	0.53 (13.5)	2.28 (58.0)
-BNH-FT4-4-3W	1/4" Tube	1/4" Tube	0.16 (4.0)	0.35	1.12 (28.4)	1.12 (28.4)	1.38 (35.0)	0.44 (11.2)	0.55 (13.9)	2.50 (63.5)
-BNH-FT6-6-3W	3/8" Tube	3/8" Tube	0.25 (6.4)	0.70	1.29 (32.8)	1.29 (32.8)	1.88 (47.8)	0.50 (12.7)	0.55 (13.9)	2.97 (75.5)
-BNH-FT8-6-3W	1/2" Tube	1/2" Tube	0.25 (6.4)	0.70	1.40 (35.6)	1.40 (35.6)	1.88 (47.8)	0.50 (12.7)	0.78 (19.8)	2.97 (75.5)
-BNH-FT8-10-3W	1/2" Tube	1/2" Tube	0.39 (10.0)	1.80	1.90 (48.3)	1.90 (48.3)	3.00 (76.2)	0.75 (19.1)	1.03 (26.2)	3.92 (99.6)
-BNH-FT12-10-3W	3/4" Tube	3/4" Tube	0.39 (10.0)	1.80	1.90 (48.3)	1.90 (48.3)	3.00 (76.2)	0.75 (19.1)	1.03 (26.2)	3.92 (99.6)
-BNH-MT3-2-3W	3 mm	3 mm	0.08 (2.0)	0.09	0.98 (25.0)	0.98 (25.0)	1.38 (35.0)	0.44 (11.2)	0.47 (11.9)	2.28 (58.0)
-BNH-MT6-4-3W	6 mm	6 mm	0.16 (4.0)	0.35	1.12 (28.4)	1.12 (28.4)	1.38 (35.0)	0.44 (11.2)	0.53 (13.5)	2.50 (63.5)
-BNH-MT8-4-3W	8 mm	8 mm	0.16 (4.0)	0.35	1.17 (29.6)	1.17 (29.6)	1.38 (35.0)	0.44 (11.2)	0.53 (13.5)	2.50 (63.5)
-BNH-MT10-6-3W	10 mm	10 mm	0.25 (6.4)	0.70	1.29 (32.8)	1.29 (32.8)	1.88 (47.8)	0.50 (12.7)	0.78 (19.8)	2.97 (75.5)
-BNH-MT12-6-3W	12 mm	12 mm	0.25 (6.4)	0.70	1.40 (35.6)	1.40 (35.6)	1.88 (47.8)	0.50 (12.7)	0.78 (19.8)	2.97 (75.5)
-BN-MT14-6-3W	14 mm	14 mm	0.25 (6.4)	0.70	1.56 (39.7)	1.56 (39.7)	1.88 (47.8)	0.50 (12.7)	0.78 (19.8)	2.97 (75.5)
-BN-MT16-10-3W	16 mm	16 mm	0.39 (10.0)	1.80	1.90 (48.3)	1.90 (48.3)	3.00 (76.2)	0.75 (19.1)	1.03 (26.2)	3.92 (99.6)
-BN-MT18-10-3W	18 mm	18 mm	0.39 (10.0)	1.80	1.90 (48.3)	1.90 (48.3)	3.00 (76.2)	0.75 (19.1)	1.03 (26.2)	3.92 (99.6)

1. Sizes and types listed are standard. Other sizes and types are available upon request, refer to the ordering information.
2. Dimensions are shown with ROKE nuts finger-tightened. All dimensions are for reference only and are subject to change.
3. For dimensions not shown above, please contact ROKE Sales department or local distributor.

Pressure vs. Temperature

BN Series

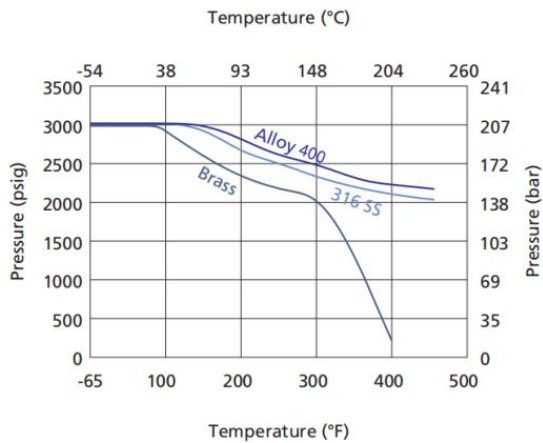

BNG Series

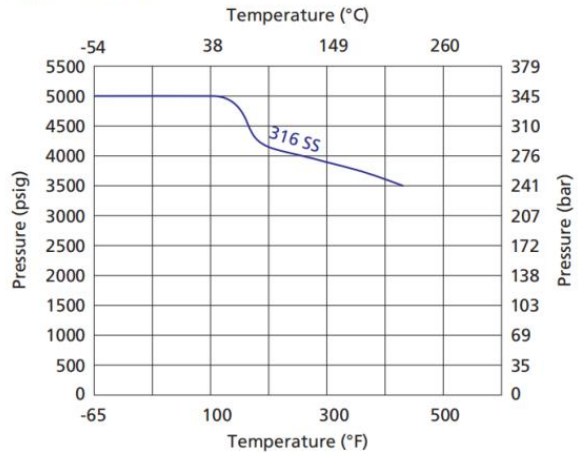

Flow Data at 100°F(38°C)

Regulating Stem

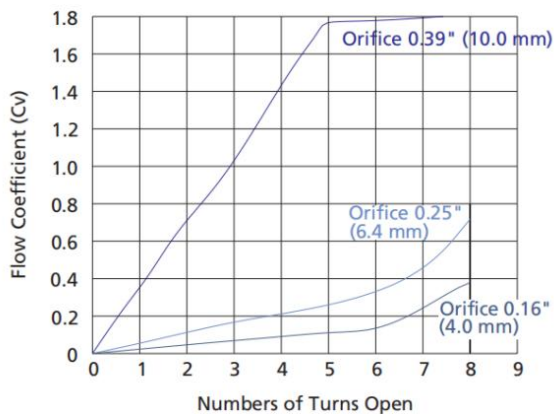

Nonrotating-stem Needle Valves

NSV Series: Maximum working pressure 3000 psig

NSH Series: Maximum working pressure 5000 psig

Features

- ⦿ One-piece forged body.
- ⦿ Nonrotating-stem.
- ⦿ Straight and angle pattern.
- ⦿ Special designed handle to stop contamination entering into the valve.
- ⦿ Leak-tight performance testing for every valve at the maximum working pressure with nitrogen.
- ⦿ Maximum working pressure:
 - NSV Series: 3000 psig (207 bar)
 - NSH Series: 5000 psig (345 bar)
- ⦿ Working temperature:
 - PCTFE: -20°F to 200°F (-28°C to 93°C)
 - PEEK: -20°F to 400°F (-28°C to 204°C)



Standard Materials of Construction

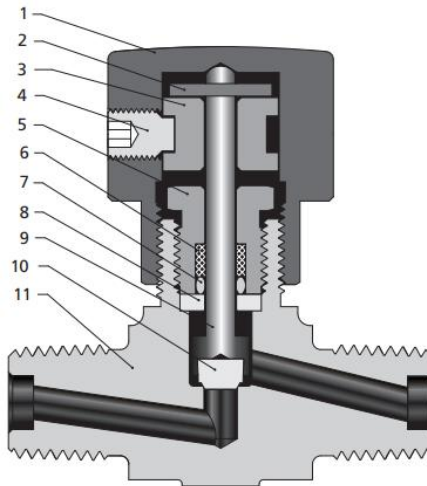

NO.	Component	Material		
		316 SS	Brass	Alloy 400
1	Handle	Anodized aluminum or stainless steel		
2	Stop Pin	Stainless steel		
3	Spool	Aluminum		
4	Set Screw	Stainless steel		
5	Packing Bolt	316 SS/A276	C36000/B16	Alloy 400/B164
6	Backup Ring	PTFE/PEEK		
7	O-ring	Fluorocarbon, Buna-N, or Ethylene propylene		
8	Washer	316 SS/A276	316 SS/A276	Alloy 400/B164
9	Stem	316 SS/A276	304 SS/A276	Alloy 400/B164
10	Stem Tip	PCTFE or PEEK		
11	Body	316 SS/A182	C36000/B16	Alloy 400/B164

⦿ Note: If you need other materials, please contact ROKE Sales department or local agent.

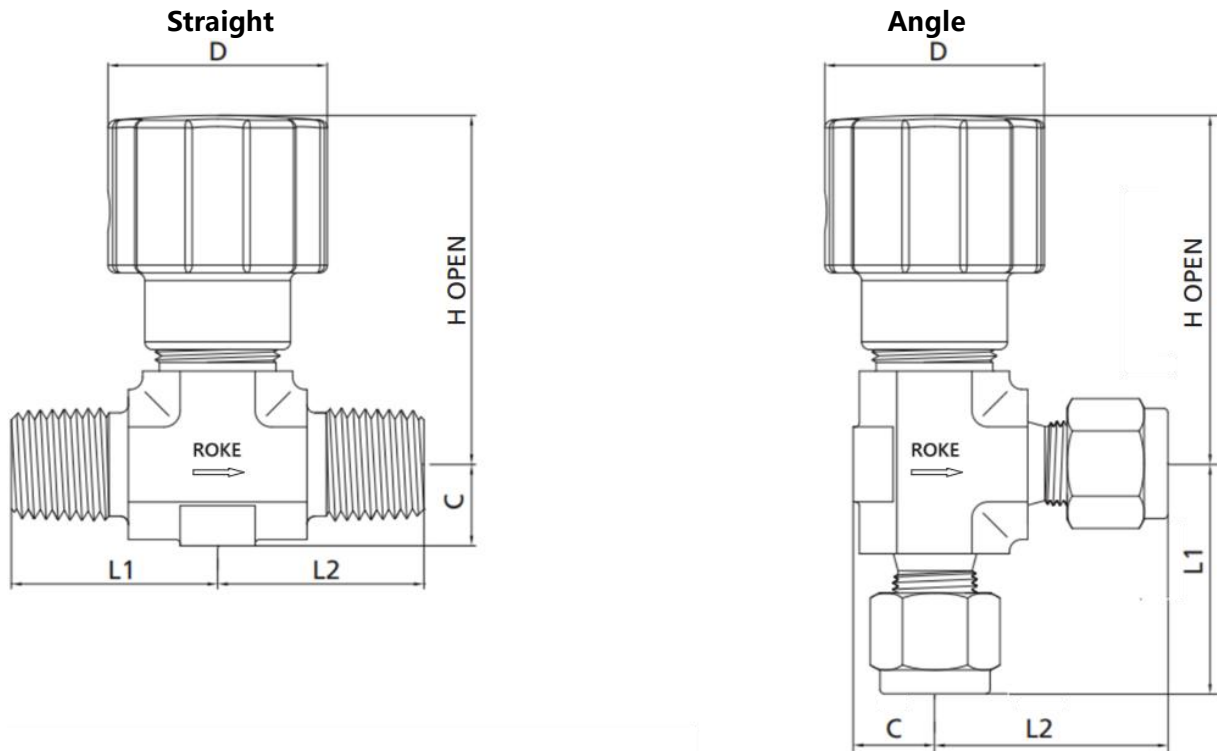

NSV Series Dimensions (3000 psig)

Basic Ordering Number	Connection Type and Size		Orifice in(mm)	Cv	Dimension, in.(mm)				
	Inlet	Outlet			L1	L2	C	D	H
-NSV-FN4-6	1/4 Female NPT	1/4 Female NPT	0.22 (5.6)	0.53	1.06 (26.9)	1.06 (26.9)	0.49 (12.5)	1.22 (31.0)	2.02 (51.3)
-NSV-MN2-2	1/8 Male NPT	1/8 Male NPT	0.08 (2.0)	0.12	0.81 (20.6)	0.81 (20.6)	0.32 (8.1)	1.06 (26.9)	1.86 (47.2)
-NSV-MN4-4	1/4 Male NPT	1/4 Male NPT	0.16 (4.0)	0.27	0.98 (25.0)	0.98 (25.0)	0.39 (10.0)	1.13 (28.7)	1.86 (47.2)
-NSV-MN6-6	3/8 Male NPT	3/8 Male NPT	0.22 (5.6)	0.53	1.12 (28.4)	1.12 (28.4)	0.49 (12.5)	1.22 (31.0)	2.02 (51.3)
-NSV-MN8-FT2-2	1/8 Male NPT	1/8" Tube	0.08 (2.0)	0.12	0.81 (20.6)	1.10 (27.9)	0.32 (8.1)	1.06 (26.9)	1.86 (47.2)
-NSV-MN4-FT4-4	1/4 Male NPT	1/4" Tube	0.16 (4.0)	0.27	0.98 (25.0)	1.13 (28.7)	0.39 (10.0)	1.13 (28.7)	1.86 (47.2)
-NSV-FT2-2	1/8" Tube	1/8" Tube	0.08 (2.0)	0.12	1.10 (27.9)	1.10 (27.9)	0.32 (8.1)	1.06 (26.9)	1.86 (47.2)
-NSV-FT4-4	1/4" Tube	1/4" Tube	0.16 (4.0)	0.27	1.13 (28.7)	1.13 (28.7)	0.39 (10.0)	1.13 (28.7)	1.86 (47.2)
-NSV-FT6-6	3/8" Tube	3/8" Tube	0.22 (5.6)	0.53	1.29 (32.8)	1.29 (32.8)	0.49 (12.5)	1.22 (31.0)	2.02 (51.3)
-NSV-FT8-6	1/2" Tube	1/2" Tube	0.22 (5.6)	0.53	1.40 (35.6)	1.40 (35.6)	0.49 (12.5)	1.22 (31.0)	2.02 (51.3)
-NSV-MT3-2	3mm Tube	3mm Tube	0.08 (2.0)	0.12	1.10 (27.9)	1.10 (27.9)	0.32 (8.1)	1.06 (26.9)	1.86 (47.2)
-NSV-MT6-4	6mm Tube	6mm Tube	0.16 (4.0)	0.27	1.13 (28.7)	1.13 (28.7)	0.39 (10.0)	1.13 (28.7)	1.86 (47.2)
-NSV-MT8-4	8mm Tube	8mm Tube	0.16 (4.0)	0.27	1.18 (30.0)	1.18 (30.0)	0.39 (10.0)	1.13 (28.7)	1.86 (47.2)
-NSV-MT10-6	10mm Tube	10mm Tube	0.22 (5.6)	0.53	1.29 (32.8)	1.29 (32.8)	0.49 (12.5)	1.22 (31.0)	2.02 (51.3)
-NSV-MT12-6	12mm Tube	12mm Tube	0.22 (5.6)	0.53	1.40 (35.6)	1.40 (35.6)	0.49 (12.5)	1.22 (31.0)	2.02 (51.3)

- Note: 1. If you want to purchase angle needle valve, please add "-A" after the Basic Ordering Number.
- 2. For dimensions not shown above, please contact ROKE Sales department or local distributor.

NSH Series Dimensions (5000 psig)

Basic Ordering Number	Connection Type and Size		Orifice in(mm)	Cv	Dimension, in.(mm)				
	Inlet	Outlet			L1	L2	C	D	H
-NSH-MN2-2	1/8 Male NPT	1/8 Male NPT	0.08 (2.0)	0.12	0.81 (20.6)	0.81 (20.6)	0.32 (8.1)	1.06 (26.9)	1.86 (47.2)
-NSH-MN4-4	1/4 Male NPT	1/4 Male NPT	0.16 (4.0)	0.27	0.98 (25.0)	0.98 (25.0)	0.39 (10.0)	1.13 (28.7)	1.98 (50.2)
-NSH-FT2-2	1/8" Tube	1/8" Tube	0.08 (2.0)	0.12	1.10 (27.9)	1.10 (27.9)	0.32 (8.1)	1.06 (26.9)	1.86 (47.2)
-NSH-FT4-4	1/4" Tube	1/4" Tube	0.16 (4.0)	0.27	1.13 (28.7)	1.13 (28.7)	0.39 (10.0)	1.13 (28.7)	1.98 (50.2)
-NSH-MT3-2	3mm Tube	3mm Tube	0.08 (2.0)	0.12	1.10 (27.9)	1.10 (27.9)	0.32 (8.1)	1.06 (26.9)	1.86 (47.2)
-NSH-MT6-4	6mm Tube	6mm Tube	0.16 (4.0)	0.27	1.13 (28.7)	1.13 (28.7)	0.39 (10.0)	1.13 (28.7)	1.98 (50.2)

- Note: 1. If you want to purchase angle needle valve, please add "-A" after the Basic Ordering Number.
- 2. For dimensions not shown above, please contact ROKE Sales department or local distributor.

Pressure vs. Temperature

NSV Series

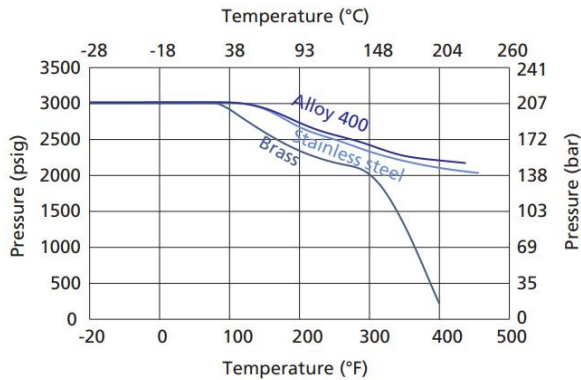

NSH Series

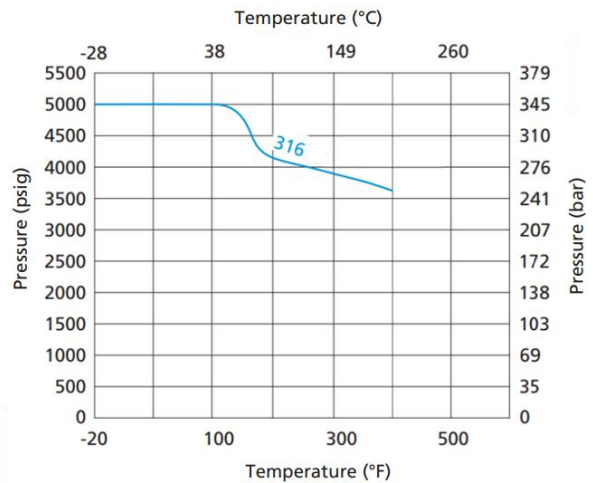

Flow Data at 100°F(38°C)

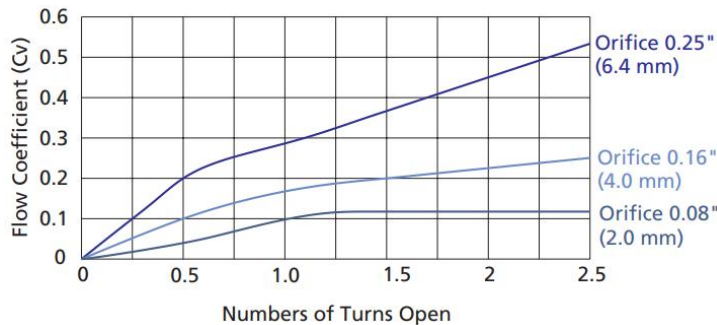

Integral Bar Stock Needle Valves

BFN Series: Maximum working pressure 6000 psig

Features

- ⦿ Cold drawn bar .
- ⦿ Panel mounting available as an option.
- ⦿ Integrated valve body structure, leak free design.
- ⦿ Handle of different colors available for option.
- ⦿ Leak-tight performance testing for every valve at the maximum working pressure with nitrogen.
- ⦿ Maximum working pressure:
 - Stainless steel: 6000 psig (414 bar)
 - Alloy C-276: 6000 psig (414 bar)
 - Alloy 400: 5000 psig (345 bar)
 - Titanium: 5000 psig (345 bar)
 - Brass: 3000 psig(207 bar)
- ⦿ Working temperature:
 - PTFE: -65°F to 450°F (-54°C to 232°C)
 - PEEK: -65°F to 500°F (-54°C to 260°C)
 - Graphite: -65°F to 1200°F(-54°C to 649°C)



Standard Materials of Construction

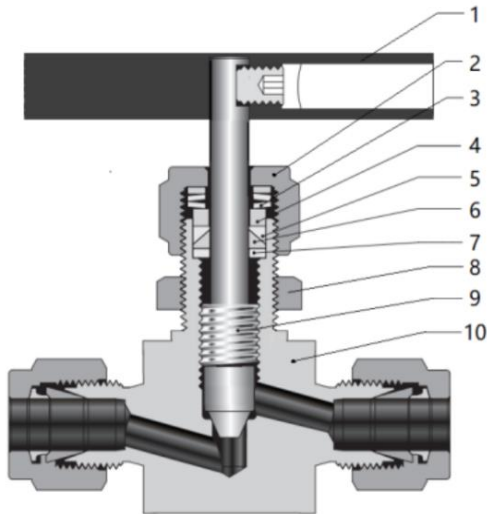

Stem Type

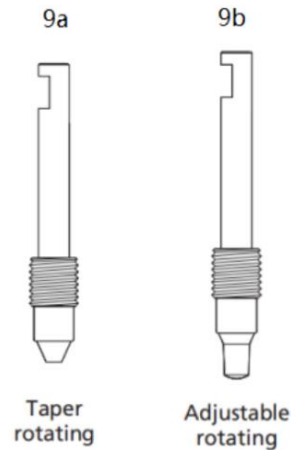

NO.	Component	Material		
		316 SS	Brass	Alloy 400
1	Handle	Anodized aluminum or stainless steel		
2	Packing Nut	316 SS/A276	Brass 36000/B16	Alloy 400/B164
3	Packing Spring	S17700/A693		
4	Upper Packing	PTFE or PEEK or graphite		
5	Lower Packing	PTFE or PEEK or graphite		
6	Set Screw	Stainless steel		
7	Packing Washer	316 SS/A276	Brass 36000/B16	Alloy 400/B164
8	Panel Nut	Stainless Steel	Brass 36000	Stainless Steel
9	Stem	316 SS/A276	304 SS/A276	Alloy 400/B164
10	Body	316 SS/A276	Brass 36000/B16	Alloy 400/B164

⦿ Note: The BFN series needle valves default to panel installation structure when leaving the factory.

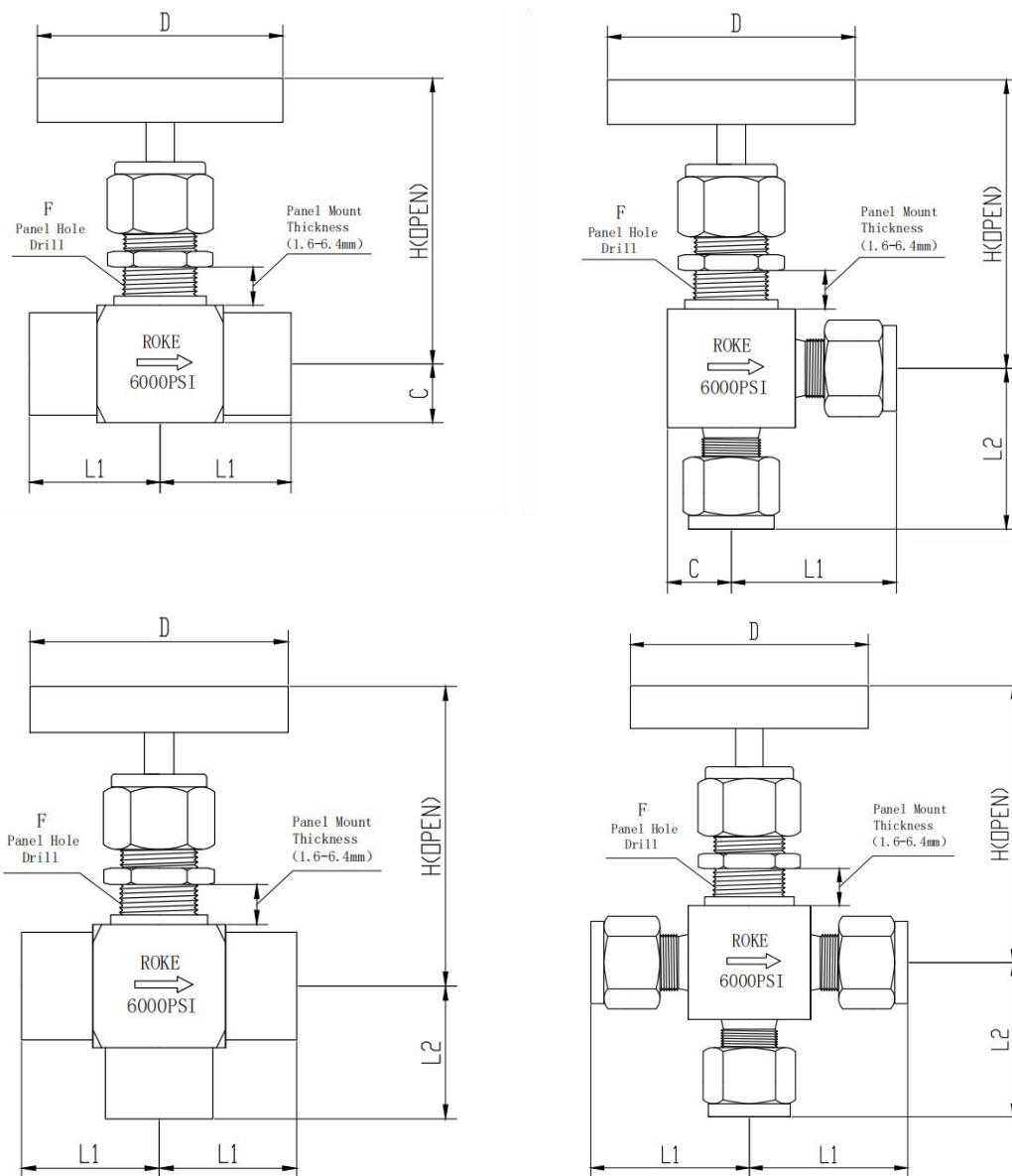

Basic Ordering Number	Connection Type and Size		Orifice in(mm)	Cv	Dimension, in.(mm)					
	Inlet	Outlet			L1	L2	C	D	F	H
-BFN-FN2-3	1/8 Female NPT	1/8 Female NPT	0.12 (3.0)	0.20	0.91 (23.0)	0.91 (23.0)	0.36 (9.1)	1.77 (45.0)	0.63 (16.0)	2.36 (60.0)
-BFN-FN4-4	1/4 Female NPT	1/4 Female NPT	0.16 (4.0)	0.35	1.06 (27.0)	1.06 (27.0)	0.45 (11.5)	2.17 (55.0)	0.67 (17.0)	2.76 (70.0)
-BFN-FN6-5	3/8 Female NPT	3/8 Female NPT	0.20 (5.1)	0.56	1.14 (29.0)	1.14 (29.0)	0.53 (13.5)	2.17 (55.0)	0.79 (20.0)	2.99 (76.0)
-BFN-FN8-6	1/2 Female NPT	1/2 Female NPT	0.25 (6.4)	0.70	1.26 (32.0)	1.26 (32.0)	0.63 (16.0)	2.50 (63.5)	0.79 (20.0)	3.38 (86.0)
-BFN-FN8-8			0.31 (7.8)	0.95	1.26 (32.0)	1.26 (32.0)	0.63 (16.0)	2.50 (63.5)	0.83 (21.0)	3.38 (86.0)
-BFN-FN12-9	3/4 Female NPT	3/4 Female NPT	0.36 (9.1)	1.60	1.34 (34.0)	1.34 (34.0)	0.73 (18.5)	2.50 (63.5)	0.83 (21.0)	3.54 (90.0)
-BFN-FN16-12	1 Female NPT	1 Female NPT	0.48 (12.2)	2.65	1.57 (40.0)	1.57 (40.0)	0.89 (22.5)	3.50 (88.9)	0.98 (25.0)	3.82 (97.0)
-BFN-MN2-3	1/8 Male NPT	1/8 Male NPT	0.12 (3.0)	0.20	0.91 (23.0)	0.981 (23.0)	0.39 (10.0)	1.77 (45.0)	0.63 (16.0)	3.23 (82.0)
-BFN-MN4-4	1/4 Male NPT	1/4 Male NPT	0.16 (4.0)	0.35	1.06 (27.0)	1.06 (27.0)	0.39 (10.0)	1.77 (45.0)	0.63 (16.0)	3.23 (82.0)
-BFN-MN6-5	3/8 Male NPT	3/8 Male NPT	0.20 (5.1)	0.56	1.14 (29.0)	1.14 (29.0)	0.47 (12.0)	2.05 (52.0)	0.63 (16.0)	3.35 (85.0)
-BFN-MN8-6	1/2 Male NPT	1/2 Male NPT	0.25 (6.4)	0.70	1.30 (33.0)	1.30 (33.0)	0.51 (13.0)	2.17 (55.0)	0.71 (18.0)	3.62 (92.0)
-BFN-MN12-7	3/4 Male NPT	3/4 Male NPT	0.31 (7.8)	0.95	1.42 (36.0)	1.42 (36.0)	0.63 (16.0)	2.17 (55.0)	0.79 (20.0)	3.78 (96.0)
-BFN-MN16-9	1 Male NPT	1 Male NPT	0.36 (9.1)	1.60	1.61 (41.0)	1.61 (41.0)	0.71 (18.0)	2.36 (60.0)	0.79 (20.0)	3.94 (100)

Basic Ordering Number	Connection Type and Size		Orifice in(mm)	Cv	Dimension, in.(mm)					
	Inlet	Outlet			L1	L2	C	D	F	H
-BFN-SW2-3	1/8 Socket Weld	1/8 Socket Weld	0.12 (3.0)	0.20	0.94 (23.8)	0.94 (23.8)	0.39 (10.0)	1.77 (45.0)	0.63 (16.0)	3.23 (82.0)
-BFN-SW4-4	1/4 Socket Weld	1/4 Socket Weld	0.16 (4.0)	0.35	0.98 (25.0)	0.98 (25.0)	0.47 (12.0)	2.05 (52.0)	0.63 (16.0)	3.35 (85.0)
-BFN-SW6-5	3/8 Socket Weld	3/8 Socket Weld	0.20 (5.1)	0.56	1.06 (27.0)	1.06 (27.0)	0.51 (13.0)	2.17 (55.0)	0.71 (18.0)	3.62 (92.0)
-BFN-SW8-6	1/2 Socket Weld	1/2 Socket Weld	0.25 (6.4)	0.70	1.14 (29.0)	1.14 (29.0)	0.63 (16.0)	2.17 (55.0)	0.71 (18.0)	3.78 (96.0)
-BFN-SW8-8			0.31 (7.8)	0.95	1.14 (29.0)	1.14 (29.0)	0.63 (16.0)	2.17 (55.0)	0.79 (20.0)	3.78 (96.0)
-BFN-SW12-9	3/4 Socket Weld	3/4 Socket Weld	0.36 (9.1)	1.60	1.14 (29.0)	1.14 (29.0)	0.71 (18.0)	2.36 (60.0)	0.79 (20.0)	3.94 (100)
-BFN-SW16-12	1 Socket Weld	1 Socket Weld	0.48 (12.2)	2.65	1.30 (33.0)	1.30 (33.0)	0.87 (22.0)	2.76 (70.0)	0.94 (24.0)	4.17 (106)
-BFN-FT2-2	1/8" Tube	1/8" Tube	0.08 (2.0)	0.09	0.98 (25.0)	0.98 (25.0)	0.39 (10.0)	1.77 (45.0)	0.63 (16.0)	3.23 (82.0)
-BFN-FT4-4	1/4" Tube	1/4" Tube	0.16 (4.0)	0.35	1.14 (29.0)	1.14 (29.0)	0.39 (10.0)	1.77 (45.0)	0.63 (16.0)	3.23 (82.0)
-BFN-FT6-5	3/8" Tube	3/8" Tube	0.20 (5.1)	0.56	1.30 (33.0)	1.30 (33.0)	0.47 (12.0)	2.05 (52.0)	0.63 (16.0)	3.35 (85.0)
-BFN-FT8-6	1/2" Tube	1/2" Tube	0.25 (6.4)	0.70	1.42 (36.0)	1.42 (36.0)	0.51 (13.0)	2.17 (55.0)	0.71 (18.0)	3.62 (92.0)
-BFN-FT12-8	3/4" Tube	3/4" Tube	0.31 (7.8)	0.95	1.89 (48.0)	1.89 (48.0)	0.63 (16.0)	2.17 (55.0)	0.79 (20.0)	3.78 (96.0)
-BFN-FT16-12	1" Tube	1" Tube	0.48 (12.2)	2.65	2.05 (52.0)	2.05 (52.0)	0.79 (20.0)	2.76 (70.0)	0.94 (24.0)	4.02 (102)
-BFN-MT3-2	3 mm Tube	3 mm Tube	0.08 (2.0)	0.09	0.98 (25.0)	0.98 (25.0)	0.39 (10.0)	1.77 (45.0)	0.63 (16.0)	3.23 (82.0)
-BFN-MT6-4	6 mm Tube	6 mm Tube	0.16 (4.0)	0.35	1.14 (29.0)	1.14 (29.0)	0.39 (10.0)	1.77 (45.0)	0.63 (16.0)	3.23 (82.0)
-BFN-MT8-4	8 mm Tube	8 mm Tube	0.16 (4.0)	0.35	1.14 (29.0)	1.14 (29.0)	0.39 (10.0)	1.77 (45.0)	0.63 (16.0)	3.23 (82.0)
-BFN-MT10-5	10 mm Tube	10 mm Tube	0.20 (5.1)	0.56	1.30 (33.0)	1.30 (33.0)	0.47 (12.0)	2.05 (52.0)	0.63 (16.0)	3.35 (85.0)
-BFN-MT12-6	12 mm Tube	12 mm Tube	0.25 (6.4)	0.70	1.42 (36.0)	1.42 (36.0)	0.51 (13.0)	2.17 (55.0)	0.71 (18.0)	3.62 (92.0)
-BFN-MT14-6	14 mm Tube	14 mm Tube	0.25 (6.4)	0.70	1.57 (40.0)	1.57 (40.0)	0.51 (13.0)	2.17 (55.0)	0.71 (18.0)	3.62 (92.0)
-BFN-MT18-8	18 mm Tube	18 mm Tube	0.31 (7.8)	0.95	1.81 (46.0)	1.81 (46.0)	0.63 (16.0)	2.17 (55.0)	0.79 (20.0)	3.78 (96.0)
-BFN-MT22-12	22 mm Tube	22 mm Tube	0.48 (12.2)	2.65	1.94 (49.5)	1.94 (49.5)	0.79 (20.0)	2.76 (70.0)	0.94 (24.0)	4.02 (102)
-BFN-MT25-12	25 mm Tube	25 mm Tube	0.48 (12.2)	2.65	2.05 (52.0)	2.05 (52.0)	0.79 (20.0)	2.76 (70.0)	0.94 (24.0)	4.02 (102)

1. Sizes and types listed are standard. Other sizes and types are available upon request, refer to the ordering information.
2. If you want to purchase angle needle valve, please add "-A" after the Basic Ordering Number.
3. Dimensions are shown with ROKE nuts finger-tightened. All dimensions are for reference only and are subject to change.
4. For dimensions not shown above, please contact ROKE Sales department or local distributor.

Pressure vs. Temperature

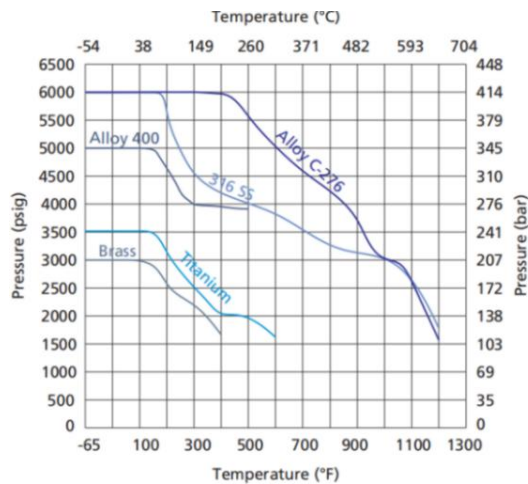

Flow Data at 100°F(38°C)

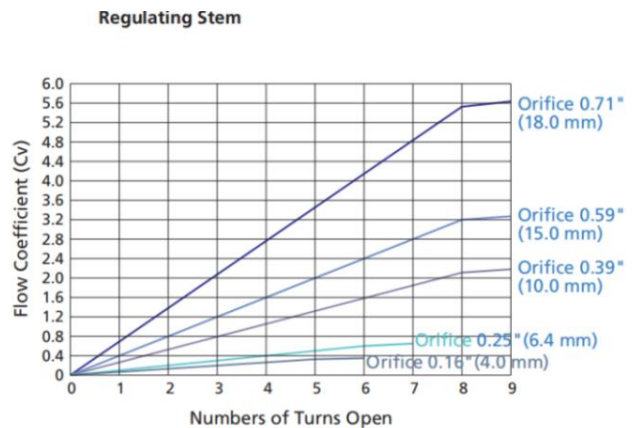

Bar Stock Needle Valves

BSN Series: Maximum working pressure 6000 psig

Features

- ⊙ Cold drawn bar .
- ⊙ Panel mounting available as an option.
- ⊙ Handle of different colors available for option.
- ⊙ Leak-tight performance testing for every valve at the maximum working pressure with nitrogen.
- ⊙ Maximum working pressure:
 - Stainless steel: 6000 psig (414 bar)
 - Alloy C-276: 6000 psig (414 bar)
 - Alloy 400: 5000 psig (345 bar)
 - Titanium: 5000 psig (345 bar)
 - Brass: 3000 psig(207 bar)
- ⊙ Working temperature:
 - PTFE: -65°F to 450°F (-54°C to 232°C)
 - PEEK: -65°F to 500°F (-54°C to 260°C)
 - Graphite: -65°F to 1200°F(-54°C to 649°C)



Standard Materials of Construction

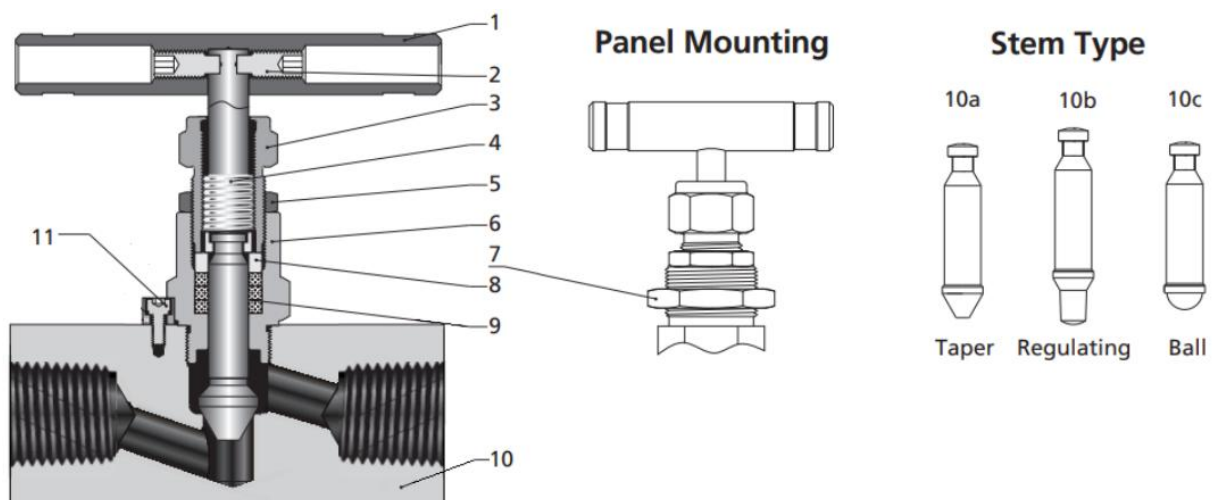

NO.	Component	Material		
		316 SS	Brass	Alloy 400
1	Handle	Anodized aluminum or stainless steel		
2	Set Screw	Stainless steel		
3	Packing Bolt	304 SS/A276	Brass 36000/B16	Alloy 400/B164
4	Stem	316 SS/A276	304 SS/A276	Alloy 400/B164
5	Lock Nut	316 SS/A276	Brass 36000/B16	316 SS/A276
6	Bonnet	316 SS/A276	Brass 36000/B16	Alloy 400/B164
7	Panel Nut	Stainless Steel	Brass 36000	Stainless Steel
8	Gland	316 SS/A276		
9	Packing	PTFE or PEEK or graphite		
10	Body	316 SS/A276	Brass 36000/B16	Alloy 400/B164
11	Lock Pin	304 SS/A276		

- ⊙ Note: The BSN series needle valves default to have no panel installation. If necessary, please add “- P” after the Basic Ordering Number. For example, SS-BSN-FN8-10-P

Dimensions

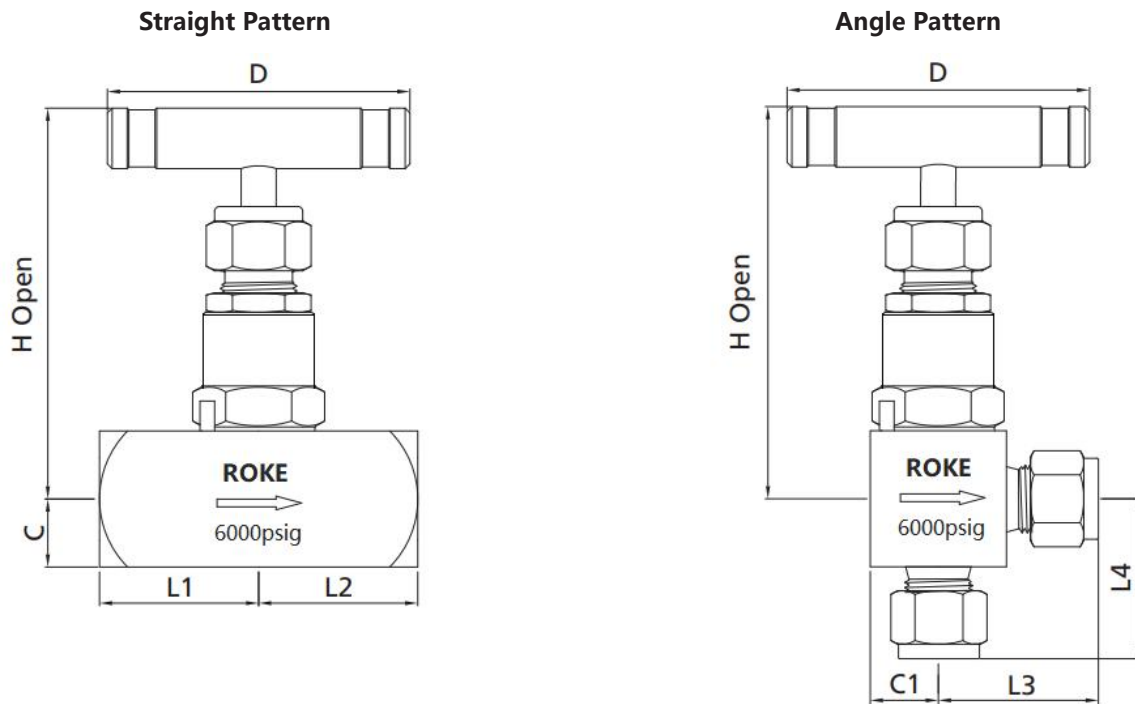

Basic Ordering Number	Connection Type & Size		Orifice in(mm)	Cv	Dimension, in.(mm)							
	Inlet	Outlet			L1	L2	L3	L4	C	C1	D	H
-BSN-FN2-4	1/8 Female NPT	1/8 Female NPT	0.16 (4.0)	0.35	1.00 (25.4)	1.00 (25.4)	1.00 (25.4)	0.56 (14.3)	0.50 (12.7)	0.50 (12.7)	2.17 (55)	2.84 (72)
-BSN-FN4-4	1/4 Female NPT	1/4 Female NPT	0.16 (4.0)	0.35	1.06 (26.9)	1.06 (26.9)	1.00 (25.4)	0.56 (14.3)	0.50 (12.7)	0.50 (12.7)	2.17 (55)	2.84 (72)
-BSN-FN4-6	1/4 Female NPT	1/4 Female NPT	0.25 (6.4)	0.85	1.12 (28.6)	1.12 (28.6)	1.12 (28.6)	0.63 (15.9)	0.56 (14.3)	0.56 (14.3)	2.56 (65.0)	3.50 (89)
-BSN-FN6-6	3/8 Female NPT	3/8 Female NPT	0.25 (6.4)	0.85	1.12 (28.6)	1.12 (28.6)	1.12 (28.6)	0.63 (15.9)	0.56 (14.3)	0.56 (14.3)	2.56 (65.0)	3.50 (89)
-BSN-FN8-6	1/2 Female NPT	1/2 Female NPT	0.25 (6.4)	0.85	1.22 (33.5)	1.22 (33.5)	1.12 (28.6)	0.63 (15.9)	0.59 (15.0)	0.56 (14.3)	2.56 (65.0)	3.50 (89)
-BSN-FN8-10	1/2 Female NPT	1/2 Female NPT	0.39 (10.0)	2.18	1.75 (44.5)	1.75 (44.5)	1.63 (41.3)	1.50 (38.1)	0.88 (22.2)	0.75 (19.1)	3.50 (89)	4.12 (105)
-BSN-FN12-10	3/4 Female NPT	3/4 Female NPT	0.39 (10.0)	2.18	1.75 (44.5)	1.75 (44.5)	1.63 (41.3)	1.50 (38.1)	0.88 (22.2)	0.75 (19.1)	3.50 (89)	4.12 (105)
-BSN-FN12-15	3/4 Female NPT	3/4 Female NPT	0.59 (15.0)	3.27	1.75 (44.5)	1.75 (44.5)	1.75 (44.5)	1.75 (44.5)	1.14 (29.0)	0.88 (22.2)	5.00 (127)	5.00 (127)
-BSN-FN16-18	1 Female NPT	1 Female NPT	0.71 (18.0)	5.65	1.97 (50.0)	1.97 (50.0)	1.97 (50.0)	1.97 (50.0)	1.25 (31.8)	1.25 (31.8)	5.00 (127)	5.20 (137)
-BFN-MN4-4	1/4 Male NPT	1/4 Male NPT	0.16 (4.0)	0.35	1.06 (26.9)	1.06 (26.9)	1.00 (25.4)	0.56 (14.3)	0.50 (12.7)	0.50 (12.7)	2.17 (55)	2.84 (72)
-BFN-MN6-4	3/8 Male NPT	3/8 Male NPT	0.16 (4.0)	0.35	1.19 (30.2)	1.19 (30.2)	1.00 (25.4)	0.56 (14.3)	0.50 (12.7)	0.50 (12.7)	2.17 (55)	2.84 (72)
-BFN-MN6-5	3/8 Male NPT	3/8 Male NPT	0.25 (6.4)	0.85	1.19 (30.2)	1.19 (30.2)	1.12 (28.6)	0.63 (15.9)	0.56 (14.3)	0.56 (14.3)	2.56 (65.0)	3.50 (89)
-BFN-MN8-6	1/2 Male NPT	1/2 Male NPT	0.25 (6.4)	0.85	1.56 (39.7)	1.56 (39.7)	1.12 (28.6)	0.63 (15.9)	0.56 (14.3)	0.56 (14.3)	2.56 (65.0)	3.50 (89)
-BFN-MN12-10	3/4 Male NPT	3/4 Male NPT	0.39 (10.0)	2.18	1.75 (44.5)	1.75 (44.5)	1.50 (38.1)	1.50 (38.1)	0.88 (22.2)	0.75 (19.1)	3.50 (89)	4.12 (105)
-BFN-MN16-15	1 Male NPT	1 Male NPT	0.59 (15.0)	3.27	1.97 (50.0)	1.97 (50.0)	1.75 (44.5)	1.75 (44.5)	1.14 (29.0)	0.88 (22.2)	5.00 (127)	5.00 (127)
-BSN-SW4-4	1/4 Socket Weld	1/4 Socket Weld	0.25 (6.4)	0.85	1.12 (28.6)	1.12 (28.6)	1.12 (28.6)	0.63 (15.9)	0.56 (14.3)	0.56 (14.3)	2.56 (65.0)	3.50 (89)
-BSN-SW6-5	3/8 Socket Weld	3/8 Socket Weld	0.25 (6.4)	0.85	1.12 (28.6)	1.12 (28.6)	1.12 (28.6)	0.63 (15.9)	0.56 (14.3)	0.56 (14.3)	2.56 (65.0)	3.50 (89)
-BSN-SW8-6	1/2 Socket Weld	1/2 Socket Weld	0.25 (6.4)	0.85	1.12 (28.6)	1.12 (28.6)	1.12 (28.6)	0.63 (15.9)	0.56 (14.3)	0.56 (14.3)	2.56 (65.0)	3.50 (89)
-BSN-SW12-9	3/4 Socket Weld	3/4 Socket Weld	0.39 (10.0)	2.18	1.75 (44.5)	1.75 (44.5)	1.63 (41.3)	1.50 (38.1)	0.88 (22.2)	0.75 (19.1)	3.50 (89)	4.12 (105)
-BSN-SW16-12	1 Socket Weld	1 Socket Weld	0.59 (15.0)	3.27	1.75 (44.5)	1.75 (44.5)	1.75 (44.5)	1.75 (44.5)	1.14 (29.0)	0.88 (22.2)	5.00 (127)	5.00 (127)

Basic Ordering Number	Connection Type & Size		Orifice in(mm)	Cv	Dimension, in.(mm)							
	Inlet	Outlet			L1	L2	L3	L4	C	C1	D	H
-BSN-FT4-4	1/4" Tube	1/4" Tube	0.16 (4.0)	0.40	1.20 (30.5)	1.20 (30.5)	1.20 (30.5)	1.20 (30.5)	0.50 (12.7)	0.50 (12.7)	2.17 (55)	2.84 (72)
-BSN-FT6-6	3/8" Tube	3/8" Tube	0.25 (6.4)	0.85	1.41 (35.8)	1.41 (35.8)	1.32 (33.6)	1.32 (33.6)	0.56 (14.3)	0.56 (14.3)	2.56 (65.0)	3.50 (89)
-BSN-FT8-6	1/2" Tube	1/2" Tube	0.25 (6.4)	0.85	1.52 (38.6)	1.52 (38.6)	1.42 (36.1)	1.42 (36.1)	0.56 (14.3)	0.56 (14.3)	2.56 (65.0)	3.50 (89)
-BSN-FT10-10	5/8" Tube	5/8" Tube	0.39 (10.0)	2.18	1.97 (50.0)	1.97 (50.0)	1.61 (41.0)	1.61 (41.0)	0.88 (22.2)	0.75 (19.1)	3.50 (89)	4.12 (105)
-BSN-FT12-10	3/4" Tube	3/4" Tube	0.39 (10.0)	2.18	1.97 (50.0)	1.97 (50.0)	1.61 (41.0)	1.61 (41.0)	0.88 (22.2)	0.75 (19.1)	3.50 (89)	4.12 (105)
-BSN-FT14-15	7/8" Tube	7/8" Tube	0.59 (15.0)	3.27	2.35 (59.7)	2.35 (59.7)	2.35 (59.7)	2.00 (50.8)	1.14 (29.0)	0.88 (22.2)	5.00 (127)	5.00 (127)
-BSN-FT16-15	1" Tube	1" Tube	0.59 (15.0)	3.27	2.61 (66.3)	2.61 (66.3)	2.61 (66.3)	2.02 (51.3)	1.14 (29.0)	0.88 (22.2)	5.00 (127)	5.00 (127)
-BSN-MT6-4	6 mm Tube	6 mm Tube	0.16 (4.0)	0.40	1.20 (30.5)	1.20 (30.5)	1.20 (30.5)	1.20 (30.5)	0.50 (12.7)	0.50 (12.7)	2.17 (55)	2.84 (72)
-BSN-MT8-4	8 mm Tube	8 mm Tube	0.16 (4.0)	0.40	1.20 (30.5)	1.20 (30.5)	1.20 (30.5)	1.20 (30.5)	0.50 (12.7)	0.50 (12.7)	2.17 (55)	2.84 (72)
-BSN-MT10-6	10 mm Tube	10 mm Tube	0.25 (6.4)	0.85	1.42 (36.1)	1.42 (36.1)	1.33 (33.8)	1.33 (33.8)	0.56 (14.3)	0.56 (14.3)	2.56 (65.0)	3.50 (89)
-BSN-MT12-6	12 mm Tube	12 mm Tube	0.25 (6.4)	0.85	1.52 (38.6)	1.52 (38.6)	1.42 (36.1)	1.42 (36.1)	0.56 (14.3)	0.56 (14.3)	2.56 (65.0)	3.50 (89)
-BSN-MT14-6	14 mm Tube	14 mm Tube	0.25 (6.4)	0.85	1.56 (39.7)	1.56 (39.7)	1.42 (36.1)	1.42 (36.1)	0.56 (14.3)	0.56 (14.3)	2.56 (65.0)	3.50 (89)
-BSN-MT16-10	16 mm Tube	16 mm Tube	0.39 (10.0)	2.18	1.97 (50.0)	1.97 (50.0)	1.61 (41.0)	1.61 (41.0)	0.88 (22.2)	0.75 (19.1)	3.50 (89)	4.12 (105)
-BSN-MT18-10	18 mm Tube	18 mm Tube	0.39 (10.0)	2.18	1.97 (50.0)	1.97 (50.0)	1.61 (41.0)	1.61 (41.0)	0.88 (22.2)	0.75 (19.1)	3.50 (89)	4.12 (105)
-BSN-MT20-15	20 mm Tube	20 mm Tube	0.39 (10.0)	2.18	1.97 (50.0)	1.97 (50.0)	1.61 (41.0)	1.61 (41.0)	0.88 (22.2)	0.75 (19.1)	3.50 (89)	4.12 (105)
-BSN-MT22-15	22 mm Tube	22 mm Tube	0.59 (15.0)	3.27	2.35 (59.7)	2.35 (59.7)	2.35 (59.7)	2.00 (50.8)	1.14 (29.0)	0.88 (22.2)	5.00 (127)	5.00 (127)
-BSN-MT25-15	25 mm Tube	25 mm Tube	0.59 (15.0)	3.27	2.61 (66.3)	2.61 (66.3)	2.61 (66.3)	2.02 (51.3)	1.14 (29.0)	0.88 (22.2)	5.00 (127)	5.00 (127)

1. Sizes and types listed are standard. Other sizes and types are available upon request, refer to the ordering information.
2. If you want to purchase angle needle valve, please add "-A" after the Basic Ordering Number.
3. Dimensions are shown with ROKE nuts finger-tightened. All dimensions are for reference only and are subject to change.
4. For dimensions not shown above, please contact ROKE Sales department or local distributor.

Pressure vs. Temperature

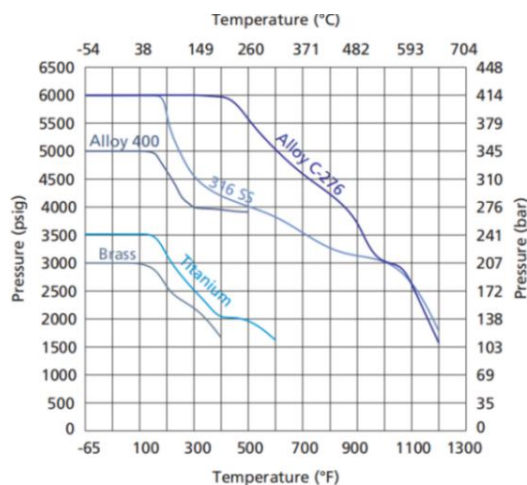

Flow Data at 100°F(38°C)

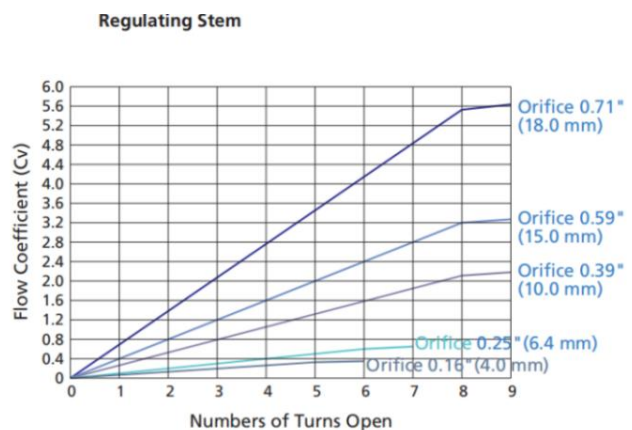

Forged Needle Valves

FNH Series: Maximum working pressure 10000 psig

Features

- One-piece forged body.
- Two-stem design: thread hardened upper stem and smooth surface hardened lower stem.
- Panel mounting available as an option.
- Handle of different colors available for option.
- Linearly instead of helical movement of the nonrotating lower stem, avoiding galling damage to packing and tip.
- Leak-tight performance testing for every valve at the maximum working pressure with nitrogen.
- Maximum working pressure: 10000 psig (689 bar)
- Working temperature:
 - PTFE: -65°F to 450°F (-54°C to 232°C)
 - PEEK: -65°F to 500°F (-54°C to 260°C)
 - Graphite: -65°F to 1200°F(-54°C to 649°C)



Standard Materials of Construction

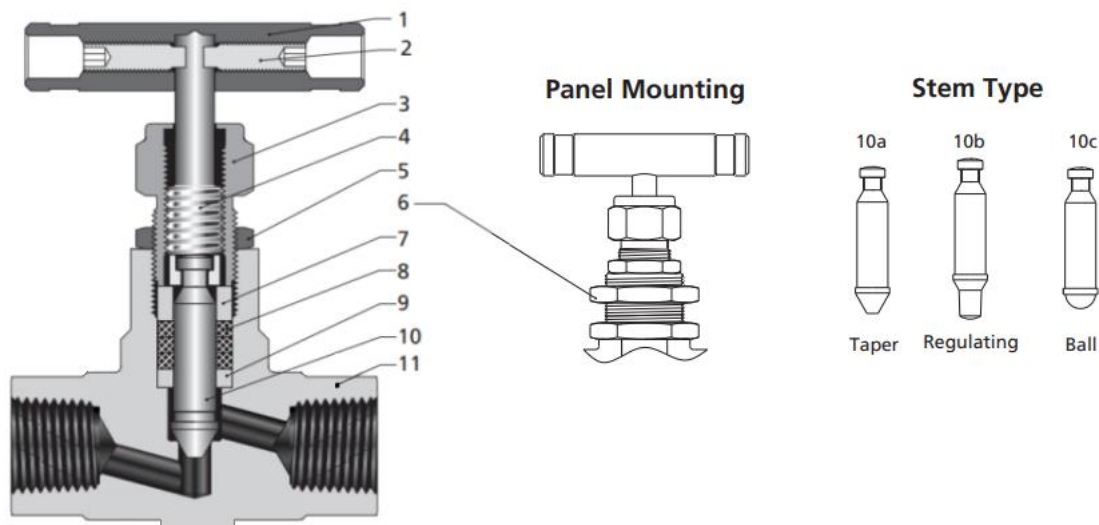

NO.	Component	Material		
		316 SS	F91	F92
1	Handle	Anodized aluminum or stainless steel		
2	Set Screw	Stainless steel		
3	Packing Bolt	316 SS/A276	F91/A182	F92/A182
4	Upper Stem	316 SS/A276	F91/A182	F92/A182
5	Lock Nut	304 SS/A276		
6	Panel Nut	304 SS/A276		
7	Gland	316 SS/A276	F91/A182	F92/A182
8	Packing	PTFE or PEEK or graphite		
9	Packing Washer	316 SS/A276	F91/A182	F92/A182
10	Lower Stem	Chrome-plated 316 SS/A276	Chrome-plated F91/A182	Chrome-plated F92/A182
11	Body	316 SS/A182	F91/A182	F92/A182

- Note: The FNH series needle valves default to have no panel installation. If necessary, please add "- P" after the Basic Ordering Number. For example, SS-FNH-FN8-10-P

Dimensions of FNH Series

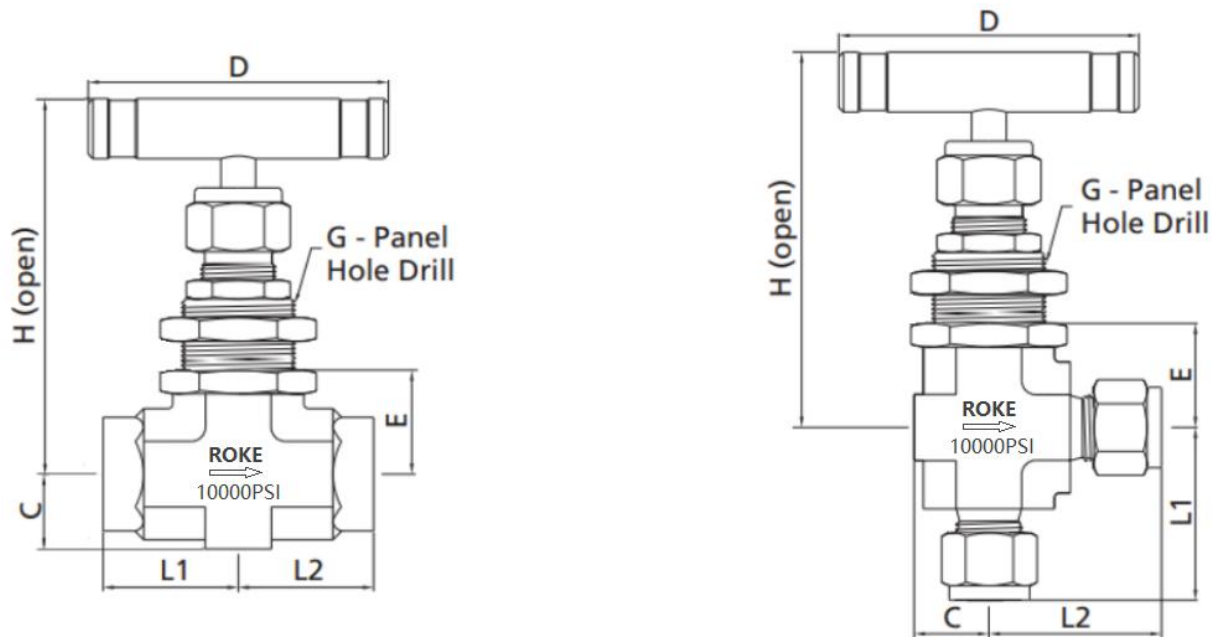

Basic Ordering Number	Connection Type and Size		Orifice in(mm)	Cv	Dimension, in.(mm)						
	Inlet	Outlet			L1	L2	C	D	E	G	H
-FNH-FN2-4	1/8 Female NPT	1/8 Female NPT	0.16 (4.0)	0.35	1.00 (25.4)	1.00 (25.4)	0.49 (12.5)	2.17 (55.0)	0.71 (18.0)	0.77 (19.6)	2.85 (72.5)
-FNH-FN4-4	1/4 Female NPT	1/4 Female NPT	0.16 (4.0)	0.35	1.03 (26.2)	1.03 (26.2)	0.49 (12.5)	2.17 (55.0)	0.71 (18.0)	0.77 (19.6)	2.85 (72.5)
-FNH-FN6-6	3/8 Female NPT	3/8 Female NPT	0.25 (6.4)	0.85	1.13 (28.6)	1.13 (28.6)	0.62 (15.8)	2.56 (65.0)	0.87 (22.0)	0.96 (24.4)	3.38 (85.8)
-FNH-FN8-6	1/2 Female NPT	1/2 Female NPT	0.25 (6.4)	0.85	1.50 (38.1)	1.50 (38.1)	0.80 (20.3)	2.56 (65.0)	0.87 (22.0)	0.96 (24.4)	3.38 (85.8)
-FNH-FN8-10	1/2 Female NPT	1/2 Female NPT	0.39 (10.0)	2.18	1.56 (39.6)	1.56 (39.6)	0.80 (20.3)	3.50 (88.9)	1.10 (28.0)	1.08 (27.5)	3.38 (85.8)
-FNH-FN12-12	3/4 Female NPT	3/4 Female NPT	0.50 (12.2)	2.65	1.58 (40.0)	1.58 (40.0)	0.80 (20.2)	3.50 (88.9)	1.10 (28.3)	1.08 (27.5)	3.78 (96.0)
-FNH-FN16-15	1 Female NPT	1 Female NPT	0.59 (15.0)	3.27	1.97 (50.0)	1.97 (50.0)	1.30 (33.0)	5.00 (127)	1.61 (41.0)	1.45 (36.8)	6.50 (165)
-FNH-FN2-4-A	1/8 Female NPT	1/8 Female NPT	0.16 (4.0)	0.35	1.00 (25.4)	1.00 (25.4)	0.49 (12.5)	2.17 (55.0)	0.71 (18.0)	0.77 (19.6)	2.85 (72.5)
-FNH-FN4-4-A	1/4 Female NPT	1/4 Female NPT	0.16 (4.0)	0.35	1.03 (26.2)	1.03 (26.2)	0.49 (12.5)	2.17 (55.0)	0.71 (18.0)	0.77 (19.6)	2.85 (72.5)
-FNH-FN6-6-A	3/8 Female NPT	3/8 Female NPT	0.25 (6.4)	0.85	1.13 (28.6)	1.13 (28.6)	0.62 (15.8)	2.56 (65.0)	0.87 (22.0)	0.96 (24.4)	3.38 (85.8)
-FNH-FN8-6-A	1/2 Female NPT	1/2 Female NPT	0.25 (6.4)	0.85	1.26 (32.0)	1.26 (32.0)	0.62 (15.8)	2.56 (65.0)	0.87 (22.0)	0.96 (24.4)	3.38 (85.8)
-FNH-FN8-10-A	1/2 Female NPT	1/2 Female NPT	0.39 (10.0)	2.18	1.56 (39.6)	1.56 (39.6)	0.80 (20.3)	3.50 (88.9)	1.10 (28.0)	1.08 (27.5)	3.38 (85.8)
-FNH-MN4-4	1/4 Male NPT	1/4 Male NPT	0.16 (4.0)	0.35	1.03 (26.2)	1.03 (26.2)	0.49 (12.5)	2.17 (55.0)	0.71 (18.0)	0.77 (19.6)	2.85 (72.5)
-FNH-MN6-5	3/8 Male NPT	3/8 Male NPT	0.25 (6.4)	0.85	1.13 (28.6)	1.13 (28.6)	0.62 (15.8)	2.56 (65.0)	0.87 (22.0)	0.96 (24.4)	3.38 (85.8)
-FNH-MN8-6	1/2 Male NPT	1/2 Male NPT	0.25 (6.4)	0.85	1.50 (38.1)	1.50 (38.1)	0.62 (15.8)	2.56 (65.0)	0.87 (22.0)	0.96 (24.4)	3.38 (85.8)
-FNH-MN12-7	3/4 Male NPT	3/4 Male NPT	0.39 (10.0)	2.18	1.97 (50.0)	1.97 (50.0)	0.80 (20.3)	3.50 (88.9)	1.10 (28.3)	1.08 (27.5)	3.86 (98.0)
-FNH-SW4-4	1/4 Socket Weld	1/4 Socket Weld	0.16 (4.0)	0.35	1.03 (26.2)	1.03 (26.2)	0.49 (12.5)	2.17 (55.0)	0.71 (18.0)	0.77 (19.6)	2.85 (72.5)
-FNH-SW6-6	3/8 Socket Weld	3/8 Socket Weld	0.25 (6.4)	0.85	1.13 (28.6)	1.13 (28.6)	0.62 (15.8)	2.56 (65.0)	0.87 (22.0)	0.96 (24.4)	3.38 (85.8)
-FNH-SW8-6	1/2 Socket Weld	1/2 Socket Weld	0.25 (6.4)	0.85	1.26 (32.0)	1.26 (32.0)	0.62 (15.8)	2.56 (65.0)	0.87 (22.0)	0.96 (24.4)	3.38 (85.8)
-FNH-SW8-10	1/2 Socket Weld	1/2 Socket Weld	0.39 (10.0)	2.18	1.56 (39.6)	1.56 (39.6)	0.80 (20.3)	3.50 (88.9)	1.10 (28.0)	1.08 (27.5)	3.38 (85.8)

Dimensions of FNH Series

Basic Ordering Number	Connection Type and Size		Orifice in(mm)	Cv	Dimension, in.(mm)						
	Inlet	Outlet			L1	L2	C	D	E	F	H
-FNH-FT4-4	1/4" Tube	1/4" Tube	0.16 (4.0)	0.35	1.22 (30.9)	1.22 (30.9)	0.49 (12.5)	2.17 (55.0)	0.71 (18.0)	0.77 (19.6)	2.85 (72.5)
-FNH-FT6-6	3/8" Tube	3/8" Tube	0.25 (6.4)	0.85	1.44 (36.5)	1.44 (36.5)	0.62 (15.8)	2.56 (65.0)	0.87 (22.0)	0.96 (24.4)	3.38 (85.8)
-FNH-FT8-6	1/2" Tube	1/2" Tube	0.25 (6.4)	0.85	1.53 (38.9)	1.53 (38.9)	0.62 (15.8)	2.56 (65.0)	0.87 (22.0)	0.96 (24.4)	3.38 (85.8)
-FNH-FT8-10	1/2" Tube	1/2" Tube	0.39 (10.0)	2.18	1.97 (50.0)	1.97 (50.0)	0.80 (20.3)	3.50 (88.9)	1.10 (28.3)	1.08 (27.5)	3.86 (98.0)
-FNH-FT4-4-A	1/4" Tube	1/4" Tube	0.16 (4.0)	0.35	1.22 (30.9)	1.22 (30.9)	0.49 (12.5)	2.17 (55.0)	0.71 (18.0)	0.77 (19.6)	2.85 (72.5)
-FNH-FT6-6-A	3/8" Tube	3/8" Tube	0.25 (6.4)	0.85	1.44 (36.5)	1.44 (36.5)	0.62 (15.8)	2.56 (65.0)	0.87 (22.0)	0.96 (24.4)	3.38 (85.8)
-FNH-FT8-6-A	1/2" Tube	1/2" Tube	0.25 (6.4)	0.85	1.53 (38.9)	1.53 (38.9)	0.62 (15.8)	2.56 (65.0)	0.87 (22.0)	0.96 (24.4)	3.38 (85.8)
-FNH-FT8-10-A	1/2" Tube	1/2" Tube	0.39 (10.0)	2.18	1.97 (50.0)	1.97 (50.0)	0.80 (20.3)	3.50 (88.9)	1.10 (28.3)	1.08 (27.5)	3.86 (98.0)
-FNH-MT6-4	6 mm Tube	6 mm Tube	0.16 (4.0)	0.35	1.22 (30.9)	1.22 (30.9)	0.49 (12.5)	2.17 (55.0)	0.71 (18.0)	0.77 (19.6)	2.85 (72.5)
-FNH-MT8-4	8 mm Tube	8 mm Tube	0.16 (4.0)	0.35	1.25 (31.8)	1.25 (31.8)	0.49 (12.5)	2.17 (55.0)	0.71 (18.0)	0.77 (19.6)	2.85 (72.5)
-FNH-MT10-6	10 mm Tube	10 mm Tube	0.25 (6.4)	0.85	1.44 (36.5)	1.44 (36.5)	0.62 (15.8)	2.56 (65.0)	0.87 (22.0)	0.96 (24.4)	3.38 (85.8)
-FNH-MT12-6	12 mm Tube	12 mm Tube	0.25 (6.4)	0.85	1.53 (38.9)	1.53 (38.9)	0.62 (15.8)	2.56 (65.0)	0.87 (22.0)	0.96 (24.4)	3.38 (85.8)
-FNH-MT12-10	12 mm Tube	12 mm Tube	0.39 (10.0)	2.18	1.97 (50.0)	1.97 (50.0)	0.80 (20.3)	3.50 (88.9)	1.10 (28.3)	1.08 (27.5)	3.86 (98.0)
-FNH-MT6-4-A	6 mm Tube	6 mm Tube	0.16 (4.0)	0.35	1.22 (30.9)	1.22 (30.9)	0.49 (12.5)	2.17 (55.0)	0.71 (18.0)	0.77 (19.6)	2.85 (72.5)
-FNH-MT8-4-A	8 mm Tube	8 mm Tube	0.16 (4.0)	0.35	1.25 (31.8)	1.25 (31.8)	0.49 (12.5)	2.17 (55.0)	0.71 (18.0)	0.77 (19.6)	2.85 (72.5)
-FNH-MT10-6-A	10 mm Tube	10 mm Tube	0.25 (6.4)	0.85	1.44 (36.5)	1.44 (36.5)	0.62 (15.8)	2.56 (65.0)	0.87 (22.0)	0.96 (24.4)	3.38 (85.8)
-FNH-MT12-6-A	12 mm Tube	12 mm Tube	0.25 (6.4)	0.85	1.53 (38.9)	1.53 (38.9)	0.62 (15.8)	2.56 (65.0)	0.87 (22.0)	0.96 (24.4)	3.38 (85.8)
-FNH-MT12-10-A	12 mm Tube	12 mm Tube	0.39 (10.0)	2.18	1.97 (50.0)	1.97 (50.0)	0.80 (20.3)	3.50 (88.9)	1.10 (28.3)	1.08 (27.5)	3.86 (98.0)

1. Sizes and types listed are standard. Other sizes and types are available upon request, refer to the ordering information.
2. If you want to purchase angle needle valve, please add "-A" after the Basic Ordering Number.
3. Dimensions are shown with ROKE nuts finger-tightened. All dimensions are for reference only and are subject to change.
4. For dimensions not shown above, please contact ROKE Sales department or local distributor.

Pressure vs. Temperature

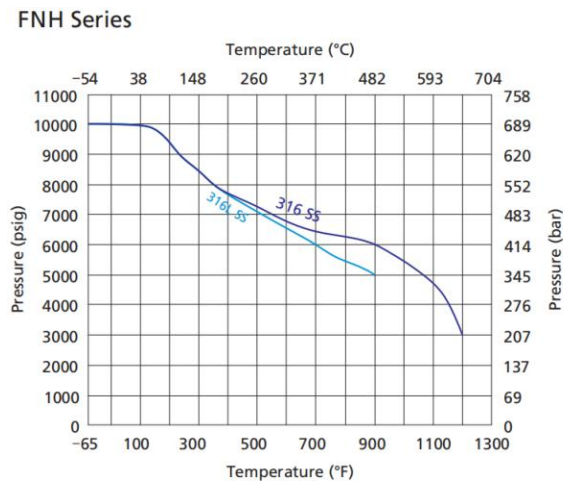

Flow Data at 100°F(38°C)

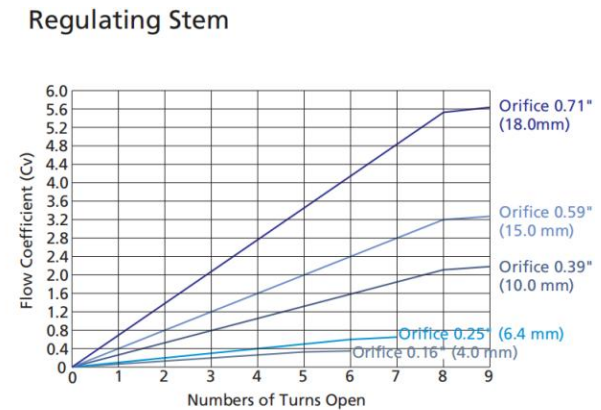

Union Bonnet Needle Valves

UN Series: Maximum working pressure 6000 psig

UNH Series: Maximum working pressure 10000 psig

Features

- One-piece forged body.
- Two-stem design: thread hardened upper stem and smooth surface hardened lower stem.
- Accidental valve disassembly disabled by union bonnet Construction.
- Safety back seating seal in fully open position.
- Panel mounting available as an option.
- Handle color options are available.
- Linearly instead of helical movement of the nonrotating lower stem, avoiding galling damage to packing and tip.
- Leak-tight performance testing for every valve at the maximum working pressure with nitrogen.
- Maximum working pressure:
 - UN Series: 6000 psig (414 bar)
 - UNH Series: 10000 psig (689 bar)
- Working temperature:
 - PTFE: -65°F to 450°F (-54°C to 232°C)
 - PEEK: -65°F to 500°F (-54°C to 260°C)
 - Graphite: -65°F to 1200°F(-54°C to 649°C)



Standard Materials of Construction

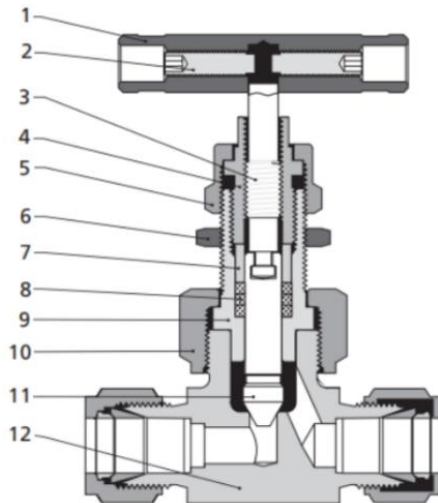

Stem Type

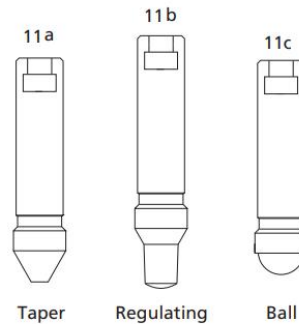

NO.	Component	Material		
		316 SS	F91	Alloy C-276
1	Handle	Anodized aluminum or stainless steel		
2	Set Screw	Stainless steel		
3	Upper Stem	316 SS/A276	F91/A182	C-276/B574
4	Packing Bolt	316 SS/A276	F91/A182	C-276/B574
5	Lock Nut	304 SS/A276		
6	Panel Nut	304 SS/A276		
7	Gland	316 SS/A276	F91/A182	C-276/B574
8	Packing	PTFE or PEEK or Graphite		
9	Bonnet	316 SS/A276	F91/A182	C-276/B574
10	Union Nut	316 SS/A276	F91/A182	C-276/B574
11	Lower Stem	Chrome-plated 316 SS/A276	Chrome-plated F91/A182	C-276/B574
12	Body	316 SS/A182	F91/A182	F92/A182

- Note: The UN/UNH series needle valves default to panel installation structure when leaving the factory.

Dimensions of UN Series Straight Pattern

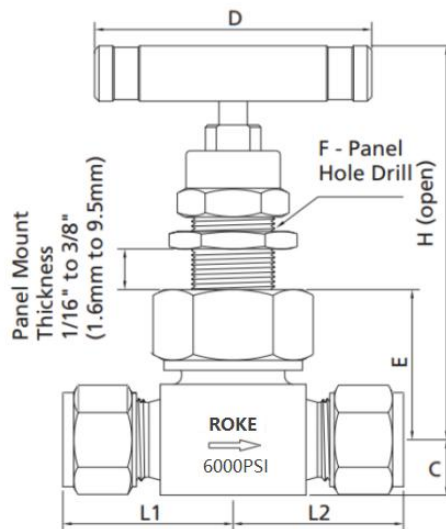

Angle Pattern

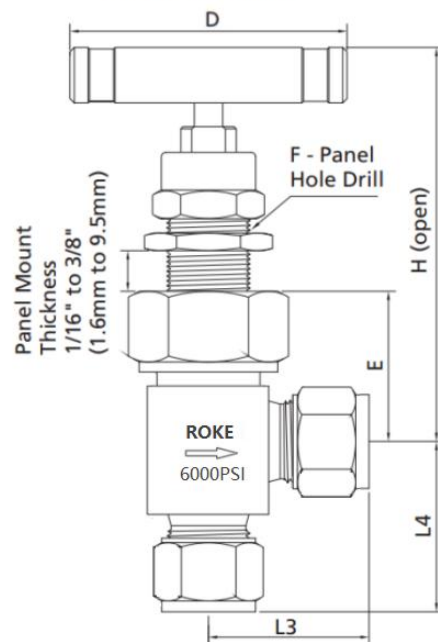

Basic Ordering Number	Connection		Orifice in.(mm)	Cv	Dimension, in.(mm)								
	Inlet	Outlet			L1	L2	L3	L4	C	D	E	F	H
-UN-FN4-4	1/4 Female NPT	1/4 Female NPT	0.16 (4.0)	0.35	1.03 (26.2)	1.03 (26.2)	0.89 (22.6)	1.00 (25.4)	0.50 (12.7)	2.56 (65.0)	1.09 (27.7)	0.59 (15.0)	3.06 (77.7)
-UN-FN4-6	1/4 Female NPT	1/4 Female NPT	0.25 (6.4)	0.80	1.13 (28.5)	1.13 (28.5)	1.00 (25.4)	1.13 (28.6)	0.53 (13.5)	2.56 (65.0)	1.34 (34.0)	0.78 (19.8)	3.70 (94.0)
-UN-FN6-6	3/8 Female NPT	3/8 Female NPT	0.25 (6.4)	0.80	1.13 (28.5)	1.13 (28.5)	1.00 (25.4)	1.13 (28.6)	0.53 (13.5)	2.56 (65.0)	1.34 (34.0)	0.78 (19.8)	3.70 (94.0)
-UN-FN8-6	1/2 Female NPT	1/2 Female NPT	0.25 (6.4)	0.80	1.42 (36.0)	1.42 (36.0)	1.00 (25.4)	1.13 (28.6)	0.53 (13.5)	2.56 (65.0)	1.34 (34.0)	0.78 (19.8)	3.70 (94.0)
-UN-FN12-10	3/4 Female NPT	3/4 Female NPT	0.39 (10.0)	1.80	1.63 (41.3)	1.63 (41.3)	-	-	0.78 (19.8)	3.50 (88.9)	1.91 (48.5)	1.03 (26.2)	4.85 (123)
-UN-FN16-10	1 Female NPT	1 Female NPT	0.39 (10.0)	1.80	1.81 (46.0)	1.81 (46.0)	-	-	1.00 (25.4)	3.50 (88.9)	2.13 (54.0)	1.03 (26.2)	5.10 (129)
-UN-MN4-4	1/4 Male NPT	1/4 Male NPT	0.16 (4.0)	0.35	1.13 (28.5)	1.13 (28.5)	0.89 (22.6)	1.00 (25.4)	0.53 (13.5)	2.56 (65.0)	1.34 (34.0)	0.78 (19.8)	3.70 (94.0)
-UN-MN6-6	3/8 Male NPT	3/8 Male NPT	0.25 (6.4)	0.80	1.13 (28.5)	1.13 (28.5)	1.00 (25.4)	1.13 (28.6)	0.53 (13.5)	2.56 (65.0)	1.34 (34.0)	0.78 (19.8)	3.70 (94.0)
-UN-MN8-10	1/2 Male NPT	1/2 Male NPT	0.39 (10.0)	1.80	1.56 (39.6)	1.56 (39.6)	1.31 (33.3)	1.56 (39.6)	0.62 (15.8)	3.50 (88.9)	1.82 (46.2)	1.03 (26.2)	4.78 (121)
-UN-MN12-10	3/4 Male NPT	3/4 Male NPT	0.39 (10.0)	1.80	1.63 (41.3)	1.63 (41.3)	-	-	0.78 (19.8)	3.50 (88.9)	1.91 (48.5)	1.03 (26.2)	4.85 (123)
-UN-MN16-10	1 Male NPT	1 Male NPT	0.39 (10.0)	1.80	1.81 (46.0)	1.81 (46.0)	-	-	1.00 (25.4)	3.50 (88.9)	2.13 (54.0)	1.03 (26.2)	5.10 (129)
-UN-SWT6-6	3/8 Socket Weld	3/8 Socket Weld	0.25 (6.4)	0.80	1.13 (28.6)	1.13 (28.6)	1.00 (25.4)	1.13 (28.6)	0.53 (13.5)	2.56 (65)	1.34 (34.0)	0.78 (19.8)	3.70 (94.0)
-UN-SWT8-10	1/2 Socket Weld	1/2 Socket Weld	0.39 (10.0)	1.80	1.56 (39.6)	1.56 (39.6)	1.31 (33.3)	1.56 (39.6)	0.62 (15.8)	3.50 (88.9)	1.82 (46.2)	1.03 (26.2)	4.78 (121)
-UN-SWT12-10	3/4 Socket Weld	3/4 Socket Weld	0.39 (10.0)	1.80	1.56 (39.7)	1.56 (39.7)	1.31 (33.3)	1.69 (42.9)	0.78 (19.8)	3.50 (88.9)	1.91 (48.5)	1.03 (26.2)	4.85 (123)
-UN-SWT16-10	1 Socket Weld	1 Socket Weld	0.39 (10.0)	1.80	1.63 (41.3)	1.63 (41.3)	-	-	1.00 (25.4)	3.50 (88.9)	2.13 (54.0)	1.03 (26.2)	5.10 (129)
-UN-SWM12-6	12 mm SW	12 mm SW	0.25 (6.4)	0.80	1.13 (28.6)	1.13 (28.6)	1.00 (25.4)	1.13 (28.6)	0.53 (13.5)	2.56 (65.0)	1.34 (34.0)	0.78 (19.8)	3.70 (94.0)
-UN-SWM14-6	14 mm SW	14 mm SW	0.25 (6.4)	0.80	1.13 (28.6)	1.13 (28.6)	1.00 (25.4)	1.13 (28.6)	0.53 (13.5)	2.56 (65.0)	1.34 (34.0)	0.78 (19.8)	3.70 (94.0)
-UN-SWM16-10	16 mm SW	16 mm SW	0.25 (6.4)	0.80	1.13 (28.6)	1.13 (28.6)	1.00 (25.4)	1.13 (28.6)	0.53 (13.5)	2.56 (65.0)	1.34 (34.0)	0.78 (19.8)	3.70 (94.0)
-UN-SWM20-10	20 mm SW	20 mm SW	0.39 (10.0)	1.80	1.56 (39.7)	1.56 (39.7)	1.31 (33.3)	1.69 (42.9)	0.78 (19.8)	3.50 (88.9)	1.91 (48.5)	1.03 (26.2)	4.85 (123)
-UN-SWM25-10	25 mm SW	25 mm SW	0.39 (10.0)	1.80	1.56 (39.7)	1.56 (39.7)	-	-	0.78 (19.8)	3.50 (88.9)	1.91 (48.5)	1.03 (26.2)	4.85 (123)

Basic Ordering Number	Connection		Orifice in.(mm)	Cv	Dimension, in.(mm)								
	Inlet	Outlet			L1	L2	L3	L4	C	D	E	F	H
-UN-BWM14-6	14 mm BW	14 mm BW	0.25 (6.4)	0.80	1.13 (28.6)	1.13 (28.6)	1.00 (25.4)	1.13 (28.6)	0.53 (13.5)	2.56 (65.0)	1.34 (34.0)	0.78 (19.8)	3.70 (94.0)
-UN-BWM16-6	16 mm BW	16 mm BW	0.25 (6.4)	0.80	1.13 (28.6)	1.13 (28.6)	1.00 (25.4)	1.13 (28.6)	0.53 (13.5)	2.56 (65.0)	1.34 (34.0)	0.78 (19.8)	3.70 (94.0)
-UN-BWM20-10	20 mm BW	20 mm BW	0.39 (10.0)	1.80	1.56 (39.7)	1.56 (39.7)	1.31 (33.3)	1.69 (42.9)	0.78 (19.8)	3.50 (88.9)	1.91 (48.5)	1.03 (26.2)	4.85 (123)
-UN-BWM25-10	25 mm BW	25 mm BW	0.39 (10.0)	1.80	1.56 (39.7)	1.56 (39.7)	-	-	0.78 (19.8)	3.50 (88.9)	1.91 (48.5)	1.03 (26.2)	4.85 (123)
-UN-FT4-4	1/4" Tube	1/4" Tube	0.16 (4.0)	0.35	1.41 (35.9)	1.41 (35.9)	1.16 (29.5)	1.48 (37.6)	0.53 (13.5)	2.56 (65.0)	1.34 (34.0)	0.78 (19.8)	3.70 (94.0)
-UN-FT6-6	3/8" Tube	3/8" Tube	0.25 (6.4)	0.80	1.44 (36.6)	1.44 (36.6)	1.59 (32.8)	1.66 (42.2)	0.53 (13.5)	2.56 (65.0)	1.34 (34.0)	0.78 (19.8)	3.70 (94.0)
-UN-FT8-6	1/2" Tube	1/2" Tube	0.25 (6.4)	0.80	1.56 (39.6)	1.56 (39.6)	1.59 (32.8)	1.66 (42.2)	0.53 (13.5)	2.56 (65.0)	1.34 (34.0)	0.78 (19.8)	3.70 (94.0)
-UN-FT12-10	3/4" Tube	3/4" Tube	0.39 (10.0)	1.80	1.97 (50.0)	1.97 (50.0)	1.68 (42.7)	2.08 (51.8)	0.62 (15.8)	3.50 (88.9)	1.82 (46.2)	1.03 (26.2)	4.78 (121)
-UN-FT16-10	1" Tube	1" Tube	0.39 (10.0)	1.80	2.04 (51.8)	2.04 (51.8)	-	-	0.78 (19.8)	3.50 (88.9)	1.91 (48.5)	1.03 (26.2)	4.85 (123)
-UN-MT6-4	6 mm Tube	6 mm Tube	0.16 (4.0)	0.35	1.41 (35.9)	1.41 (35.9)	1.16 (29.5)	1.48 (37.6)	0.53 (13.5)	2.56 (65.0)	1.34 (34.0)	0.78 (19.8)	3.70 (94.0)
-UN-MT8-4	8 mm Tube	8 mm Tube	0.16 (4.0)	0.35	1.41 (35.9)	1.41 (35.9)	1.16 (29.5)	1.48 (37.6)	0.53 (13.5)	2.56 (65.0)	1.34 (34.0)	0.78 (19.8)	3.70 (94.0)
-UN-MT10-6	10 mm Tube	10 mm Tube	0.25 (6.4)	0.80	1.41 (35.9)	1.41 (35.9)	1.59 (32.8)	1.66 (42.2)	0.53 (13.5)	2.56 (65.0)	1.34 (34.0)	0.78 (19.8)	3.70 (94.0)
-UN-MT12-6	12 mm Tube	12 mm Tube	0.25 (6.4)	0.80	1.52 (38.6)	1.52 (38.6)	1.59 (32.8)	1.66 (42.2)	0.53 (13.5)	2.56 (65.0)	1.34 (34.0)	0.78 (19.8)	3.70 (94.0)
-UN-MT14-6	14 mm Tube	14 mm Tube	0.39 (10.0)	1.80	1.97 (50.0)	1.97 (50.0)	1.68 (42.7)	2.08 (51.8)	0.62 (15.8)	3.50 (88.9)	1.82 (46.2)	1.03 (26.2)	4.78 (121)
-UN-MT18-10	18 mm Tube	18 mm Tube	0.39 (10.0)	1.80	1.97 (50.0)	1.97 (50.0)	1.68 (42.7)	2.08 (51.8)	0.62 (15.8)	3.50 (88.9)	1.82 (46.2)	1.03 (26.2)	4.78 (121)
-UN-MT20-10	20 mm Tube	20 mm Tube	0.39 (10.0)	1.80	1.97 (50.0)	1.97 (50.0)	1.68 (42.7)	2.08 (51.8)	0.62 (15.8)	3.50 (88.9)	1.82 (46.2)	1.03 (26.2)	4.78 (121)
-UN-MT25-10	25 mm Tube	25 mm Tube	0.39 (10.0)	1.80	2.04 (51.8)	2.04 (51.8)	-	-	0.78 (19.8)	3.50 (88.9)	1.91 (48.5)	1.03 (26.2)	4.85 (123)

Dimensions of UNH Series

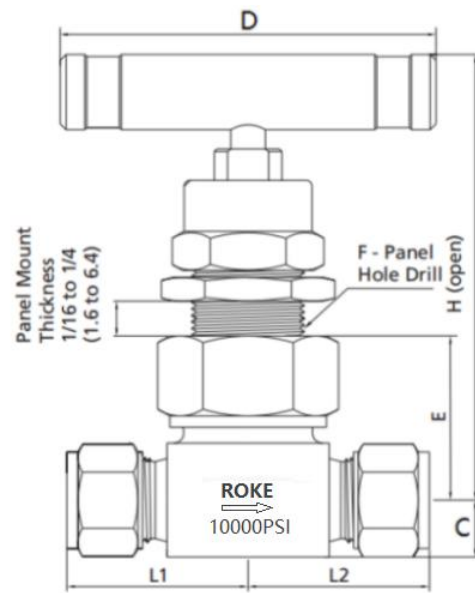
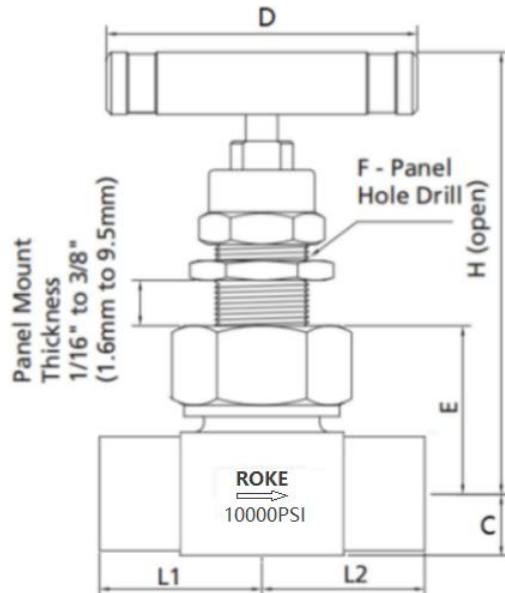

Basic Ordering Number	Connection Type and Size		Orifice in.(mm)	Cv	Dimension, in.(mm)						
	Inlet	Outlet			L1	L2	C	D	E	F	H
-UNH-FN2-4	1/8 Female NPT	1/8 Female NPT	0.16 (4.0)	0.35	1.00 (25.4)	1.00 (25.4)	0.53 (13.5)	2.56 (65.0)	1.34 (34.1)	0.78 (19.8)	3.70 (94.0)
-UNH-FN4-4	1/4 Female NPT	1/4 Female NPT	0.16 (4.0)	0.35	1.13 (28.6)	1.13 (28.6)	0.53 (13.5)	2.56 (65.0)	1.34 (34.1)	0.78 (19.8)	3.70 (94.0)
-UNH-FN6-6	3/8 Female NPT	3/8 Female NPT	0.25 (6.4)	0.80	1.38 (35.0)	1.38 (35.0)	0.53 (13.5)	2.56 (65.0)	1.34 (34.1)	0.78 (19.8)	3.70 (94.0)
-UNH-FN8-10	1/2 Female NPT	1/2 Female NPT	0.39 (10.0)	1.80	1.63 (41.4)	1.63 (41.4)	0.78 (19.8)	3.50 (88.9)	1.90 (48.3)	1.03 (26.2)	4.80 (122)

Basic Ordering Number	Connection Type and Size		Orifice in(mm)	Cv	Dimension, in.(mm)						
	Inlet	Outlet			L1	L2	C	D	E	F	H
-UNH-MN4-4	1/4 Male NPT	1/4 Male NPT	0.16 (4.0)	0.35	1.13 (28.6)	1.13 (28.6)	0.53 (13.5)	2.56 (65)	1.34 (34.0)	0.78 (19.8)	3.70 (94.0)
-UNH-MN6-6	3/8 Male NPT	3/8 Male NPT	0.25 (6.4)	0.80	1.38 (35.0)	1.38 (35.0)	0.62 (15.9)	3.50 (88.9)	1.77 (45.0)	1.03 (26.2)	4.85 (123)
-UNH-MN8-6	1/2 Male NPT	1/2 Male NPT	0.25 (6.4)	0.80	1.56 (39.6)	1.56 (39.6)	0.62 (15.9)	3.50 (88.9)	1.77 (45.0)	1.03 (26.2)	4.90 (124)
-UNH-SWT4-4	1/4 Socket Weld	1/4 Socket Weld	0.16 (4.0)	0.35	1.13 (28.6)	1.13 (28.6)	0.53 (13.5)	2.56 (65.0)	1.34 (34.0)	0.78 (19.8)	3.70 (94.0)
-UNH-SWT6-6	3/8 Socket Weld	3/8 Socket Weld	0.25 (6.4)	0.80	1.38 (35.0)	1.38 (35.0)	0.53 (13.5)	2.56 (65.0)	1.34 (34.0)	0.78 (19.8)	3.70 (94.0)
-UNH-SWT8-6	1/2 Socket Weld	1/2 Socket Weld	0.25 (6.4)	0.80	1.56 (39.7)	1.56 (39.7)	0.53 (13.5)	2.56 (65.0)	1.34 (34.0)	0.78 (19.8)	3.70 (94.0)
-UNH-SWM12-6	12 mm SW	12 mm SW	0.25 (6.4)	0.80	1.56 (39.7)	1.56 (39.7)	0.53 (13.5)	2.56 (65.0)	1.34 (34.0)	0.78 (19.8)	3.70 (94.0)
-UNH-SWM14-6	14 mm SW	14 mm SW	0.25 (6.4)	0.80	1.56 (39.7)	1.56 (39.7)	0.53 (13.5)	2.56 (65.0)	1.34 (34.0)	0.78 (19.8)	3.70 (94.0)
-UNH-FT4-4	1/4" Tube	1/4" Tube	0.16 (4.0)	0.35	1.41 (35.9)	1.41 (35.9)	0.53 (13.5)	2.56 (65)	1.34 (34.0)	0.78 (19.8)	3.70 (94.0)
-UNH-FT6-6	3/8" Tube	3/8" Tube	0.25 (6.4)	0.80	1.52 (38.6)	1.52 (38.6)	0.62 (15.9)	3.50 (88.9)	1.82 (46.2)	1.03 (26.2)	4.78 (121)
-UNH-FT8-6	1/2" Tube	1/2" Tube	0.25 (6.4)	0.80	1.97 (50.0)	1.97 (50.0)	0.78 (19.8)	3.50 (88.9)	1.93 (49.0)	1.03 (26.2)	4.85 (123)
-UNH-MT6-4	6 mm Tube	6 mm Tube	0.16 (4.0)	0.35	1.41 (35.9)	1.41 (35.9)	0.53 (13.5)	2.56 (65)	1.34 (34.0)	0.78 (19.8)	3.70 (94.0)
-UNH-MT10-6	10 mm Tube	10 mm Tube	0.25 (6.4)	0.80	1.52 (38.6)	1.52 (38.6)	0.62 (15.9)	3.50 (88.9)	1.82 (46.2)	1.03 (26.2)	4.78 (121)
-UN-MT12-6	12 mm Tube	12 mm Tube	0.25 (6.4)	0.80	1.97 (50.0)	1.97 (50.0)	0.78 (19.8)	3.50 (88.9)	1.93 (49.0)	1.03 (26.2)	4.25 (108)

1. Sizes and types listed are standard. Other sizes and types are available upon request, refer to the ordering information.
2. If you want to purchase angle needle valve, please add "-A" after the Basic Ordering Number.
3. Dimensions are shown with ROKE nuts finger-tightened. All dimensions are for reference only and are subject to change.
4. For dimensions not shown above, please contact ROKE Sales department or local distributor.

Pressure vs. Temperature

UN Series

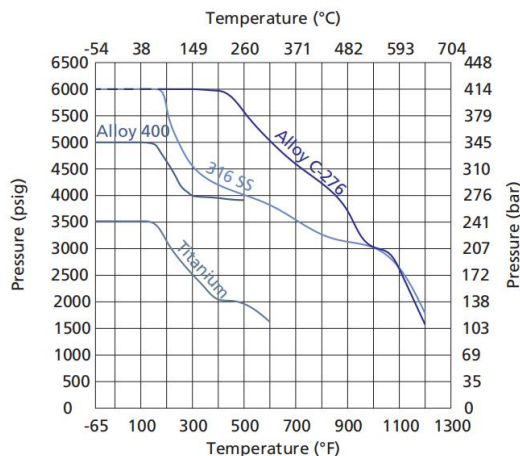

UNF Series

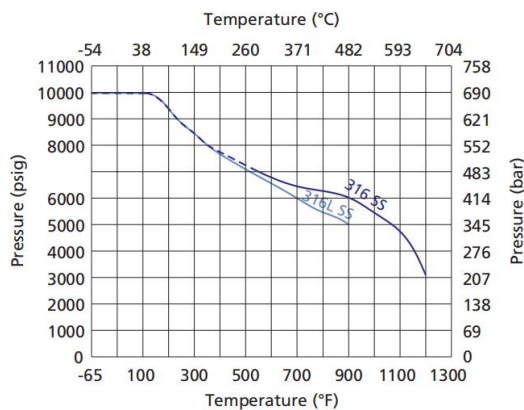

Flow Data at 100°F (37°C)

Regulating Stem

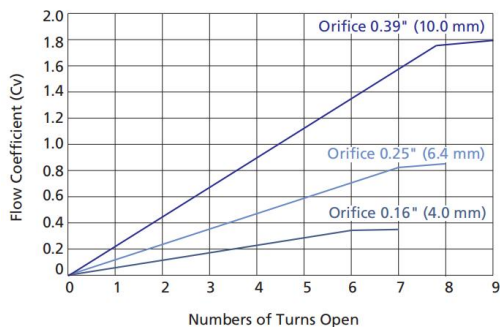

Rising Plug Valves

RP Series

RPG Series (With gauge port)

Features

- Cold drawn square bar.
- Two-stem design: thread hardened upper stem and smooth surface hardened lower stem.
- Roddable, straight through flow path for maximum flow with minimum pressure drop.
- Replaceable seat and stem tip design.
- Stem thread protected from outside contamination by PTFE ring in the gland.
- Panel mounting available as an option.
- Handle color options are available.
- Leak-tight performance testing for every valve at the maximum working pressure with nitrogen.
- Maximum working pressure: 6000 psig (414 bar)
- Working temperature:
 - PTFE: -20°F to 250°F (-28°C to 120°C)
 - PEEK: -20°F to 400°F (-28°C to 204°C)
 - PFA: -20°F to 400°F (-28°C to 204°C)



Standard Materials of Construction

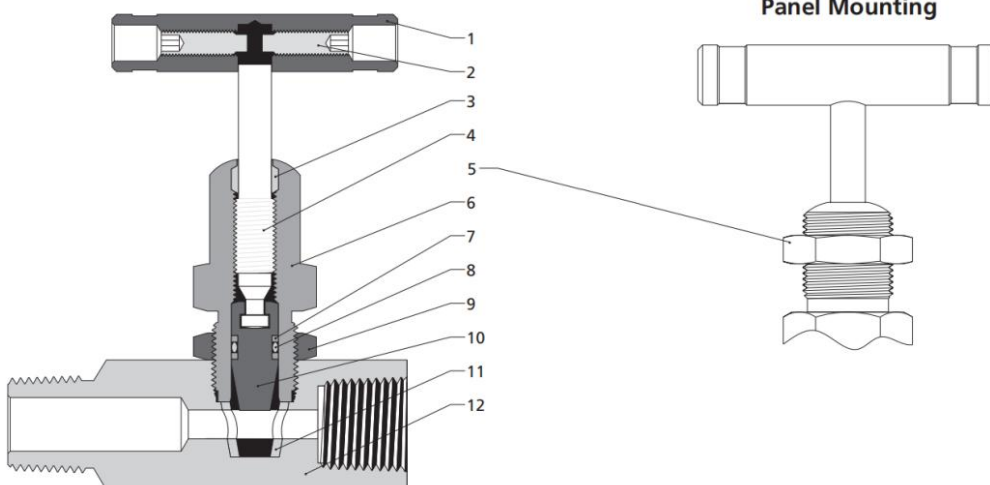

NO.	Component	Material		
		316 SS	304 SS	Alloy C-276
1	Handle	Anodized aluminum or stainless steel		
2	Set Screw	Stainless steel		
3	Wiper Ring	PTFE/D1710		
4	Upper Stem	316 SS/A276	304 SS/A276	C-276/B574
5	Panel Nut	304 SS/A276		
6	Bonnet	316 SS/A276	304 SS/A276	C-276/B574
7	Backup Ring	PTFE/D1710		
8	O-ring	Fluorocarbon FKM or Ethylene propylene		
9	Lock Nut	304 SS/A276		
8	Packing	PTFE or PEEK or graphite		
10	Stem Tip	Chrome-plated 316 SS/A276	Chrome-plated 304 SS/A276	C-276/B574
11	Seat	Acetal or PEEK or PFA		
12	Body	316 SS/A276	304 SS/A276	C-276/B574

• Note: The RP/RPG series valves default to have no panel installation. If necessary, please add "- P" after the Basic Ordering Number. For example, SS-RP-FN8-6-P

Dimensions of RP/RPG Series

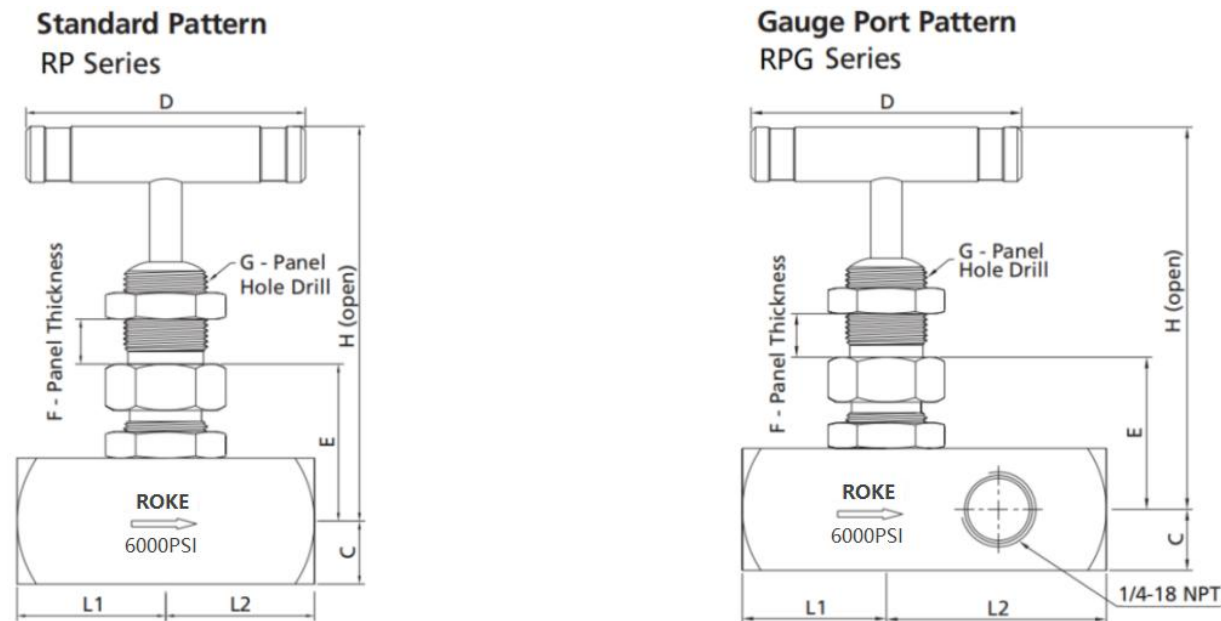

Basic Ordering Number	Connection Type and Size		Orifice in(mm)	Cv	Dimension, in.(mm)							
	Inlet	Outlet			L1	L2	C	D	E	F	G	H
-RP-FN4-4	1/4 Female NPT	1/4 Female NPT	0.16 (4.0)	0.63	1.12 (28.4)	1.13 (28.6)	0.44 (11.1)	2.17 (55.0)	1.08 (27.5)	0.25 (6.4)	0.65 (16.0)	3.77 (95.8)
-RP-MN4-FN4-4	1/4 Male NPT	1/4 Female NPT	0.16 (4.0)	0.63	1.12 (28.4)	1.13 (28.6)	0.44 (11.1)	2.17 (55.0)	1.08 (27.5)	0.25 (6.4)	0.65 (16.0)	3.77 (95.8)
-RP-MN8-FN4-4	1/2 Male NPT	1/4 Female NPT	0.16 (4.0)	0.63	1.89 (48.0)	1.13 (28.6)	0.44 (11.1)	2.17 (55.0)	1.08 (27.5)	0.25 (6.4)	0.65 (16.0)	3.77 (95.8)
-RP-FN8-6	1/2 Female NPT	1/2 Female NPT	0.25 (6.4)	1.80	1.33 (33.8)	1.33 (33.8)	0.56 (14.3)	2.56 (65.0)	1.40 (35.5)	0.38 (9.7)	0.77 (19.6)	3.83 (97.3)
-RP-MN8-FN8-6	1/2 Male NPT	1/2 Female NPT	0.25 (6.4)	1.80	2.16 (55.0)	1.33 (33.8)	0.56 (14.3)	2.56 (65.0)	1.40 (35.5)	0.38 (9.7)	0.77 (19.6)	3.83 (97.3)
-RP-MN12-FN8-6	3/4 Male NPT	1/2 Female NPT	0.25 (6.4)	1.80	2.16 (55.0)	1.33 (33.8)	0.56 (14.3)	2.56 (65.0)	1.40 (35.5)	0.38 (9.7)	0.77 (19.6)	3.83 (97.3)
-RPG-FN4-4	1/4 Female NPT	1/4 Female NPT	0.16 (4.0)	0.63	1.12 (28.4)	1.75 (44.4)	0.50 (12.7)	2.17 (55.0)	1.08 (27.5)	0.25 (6.4)	0.65 (16.0)	3.77 (95.8)
-RPG-MN8-FN4-4	1/2 Male NPT	1/4 Female NPT	0.16 (4.0)	0.63	1.89 (48.0)	1.75 (44.4)	0.50 (12.7)	2.17 (55.0)	1.08 (27.5)	0.25 (6.4)	0.65 (16.0)	3.77 (95.8)
-RPG-FN8-6	1/2 Female NPT	1/2 Female NPT	0.25 (6.4)	1.80	1.33 (33.8)	2.25 (57.2)	0.56 (14.3)	2.56 (65.0)	1.40 (35.5)	0.38 (9.7)	0.77 (19.6)	3.83 (97.3)
-RPG-MN12-FN8-6	3/4 Male NPT	1/2 Female NPT	0.25 (6.4)	1.80	2.16 (55.0)	2.25 (57.2)	0.56 (14.3)	2.56 (65.0)	1.40 (35.5)	0.38 (9.7)	0.77 (19.6)	3.83 (97.3)

1. Sizes and types listed are standard. Other sizes and types are available upon request, refer to the ordering information.
2. Dimensions are shown with ROKE nuts finger-tightened. All dimensions are for reference only and are subject to change.
3. For dimensions not shown above, please contact ROKE Sales department or local distributor.

Pressure vs. Temperature

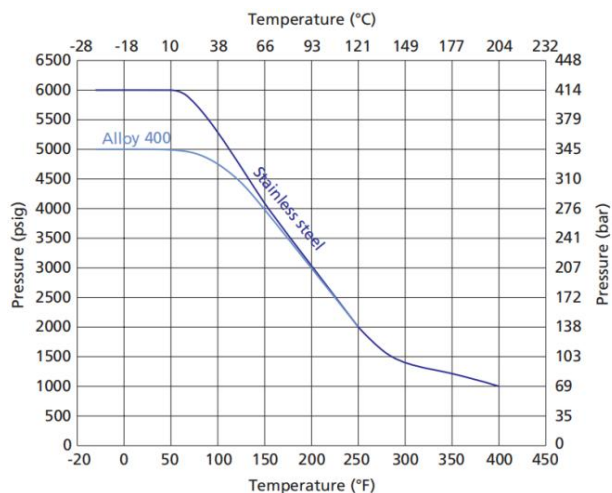

Flow Data at 100°F(38°C)

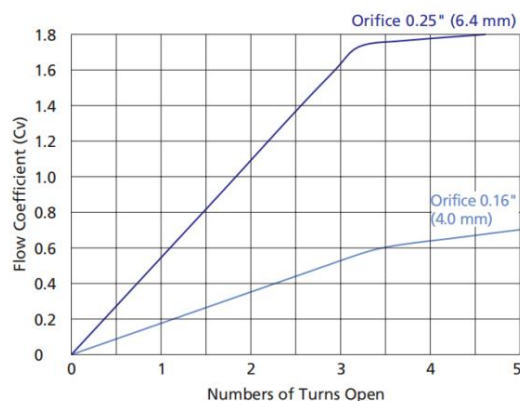

Gauge Valves

GVB Series

GVP Series

Features

- ⦿ Cold drawn square bar.
- ⦿ Non-rotating lower stem, ball tip and plug tip designs.
- ⦿ Variety of materials for seat and packing.
- ⦿ Safety back seating seals in fully open position.
- ⦿ Rolled spindle operating threads.
- ⦿ Lubricant for stem thread isolated from the media .
- ⦿ Bonnet locking pin fitted as standard
- ⦿ Low torque operating T bar handle
- ⦿ Leak-tight performance testing for every valve at the maximum working pressure with nitrogen.
- ⦿ Maximum working pressure: 6000 psig (414 bar)
- ⦿ Working temperature:
 - GVB Series PTFE: -65°F to 450°F (-54°C to 232°C)
 - Graphite: -65 F to 1200 F (-54 C to 649 C)
 - GVP Series Acetal seat: -20 F to 250 F (-28 C to 121 C)
 - PEEK Seat: -20°F to 400°F (-28°C to 204°C)
 - PFA Seat: -20°F to 400°F(-28°C to 204°C)



Standard Materials of Construction

		Valve Body Material	
Item	Part	SS 316	Alloy 400
1	Handle	Anodized aluminum	
2	Set Screw	Stainless steel	
3	Packing Bolt	SS 304	
4	Upper Stem	SS 316	
5	Lock Nut	17-4PH	
6	Bonnet	SS 316	Alloy 400
7	Gland	SS316	
8	Packing	PTFE or graphite	
9	Lock Pin	Stainless steel	
10	Lower Stem	SS 316	Alloy 400
11	Body	SS 316	Alloy 400
12	Seat	Acetal or PEEK or PFA	

⦿ Note: The GVB/GVP series gauge valves default to have no panel installation. If necessary, please add "- P" after the Basic Ordering Number. For example, SS-GVB-MN8-FN8-P

Miniature Type

Basic Ordering NO.	Inlet/ Process	Outlet/ Instrument	Vent	Orifice in(mm)	Cv	
-GVB-MN8-FN8-M	1/2 Male NPT	1/2 Female NPT	Vent Stem	0.25 (6.4)	0.9	
-GVP-MN8-FN8-M				0.25 (6.4)	1.8	

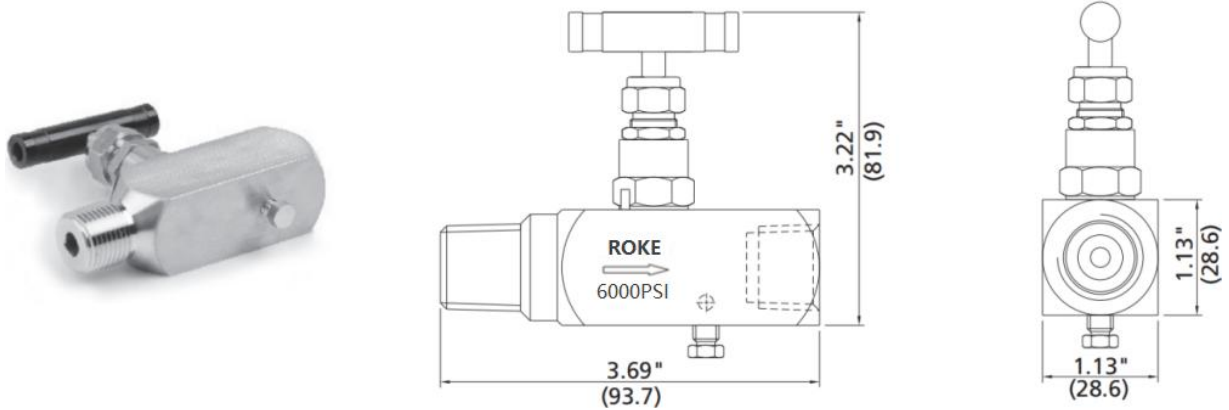

Standard Type

Basic Ordering NO.	Inlet/ Process	Outlet/ Instrument	Test/Vent /Plug	Orifice in(mm)	Cv	
-GVB-MN8-FN8	1/2 Male NPT	1/2 Female NPT	1/2 Female	0.25 (6.4)	1.0	
-GVP-MN8-FN8			NPT	0.25 (6.4)	1.8	
-GVB-MN12-FN12	3/4 Male NPT	3/4 Female NPT	1/2 Female	0.25 (6.4)	1.0	
-GVP-MN12-FN12			NPT	0.25 (6.4)	1.8	

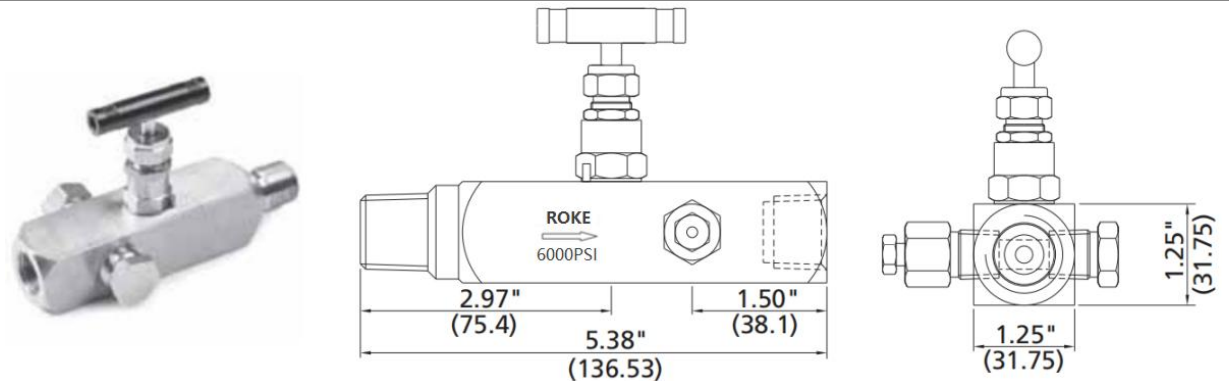

Lagging Extension Body Type

Basic Ordering NO.	Inlet/ Process	Outlet/ Instrument	Vent	Orifice in(mm)	Cv	
-GVB-MN8-FN8-L	1/2 Male NPT	1/2 Female NPT	Vent Stem	0.25 (6.4)	1.2	
-GVP-MN8-FN8-L				0.25 (6.4)	1.8	

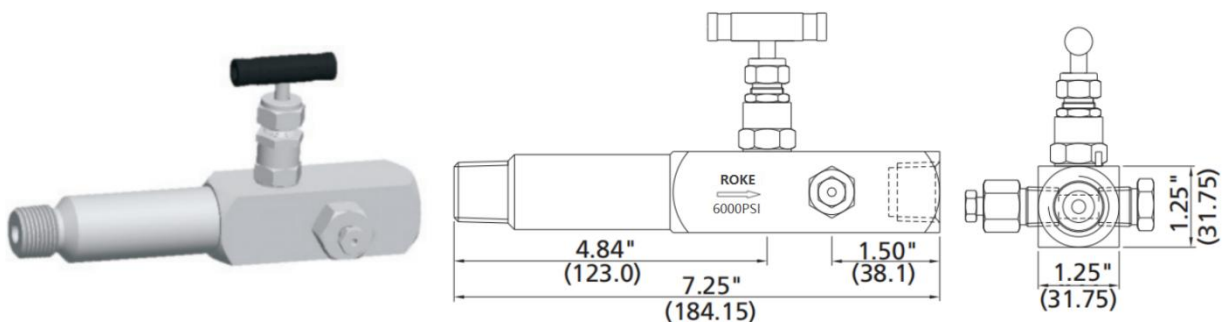

Bleed Valves

BDV Series: Maximum working pressure 10000 psig

Features

- Bleed valves can be used on instrument devices such as or gauge valves to vent signal line pressure to atmosphere before removal of an instrument or to assist in calibration.
- Variety of end connections.
- Hardened stem and tip to extend cycle life.
- Leak-tight performance testing with Nitrogen or compressed air for every valve at the rated pressure (not higher than 6000 psig) to meet the requirement of no visible leak.
- Maximum working pressure: 10000 psig (690 bar)
- Working temperature: -65°F to 850°F (-54°C to 454°C)



Standard Materials of Construction

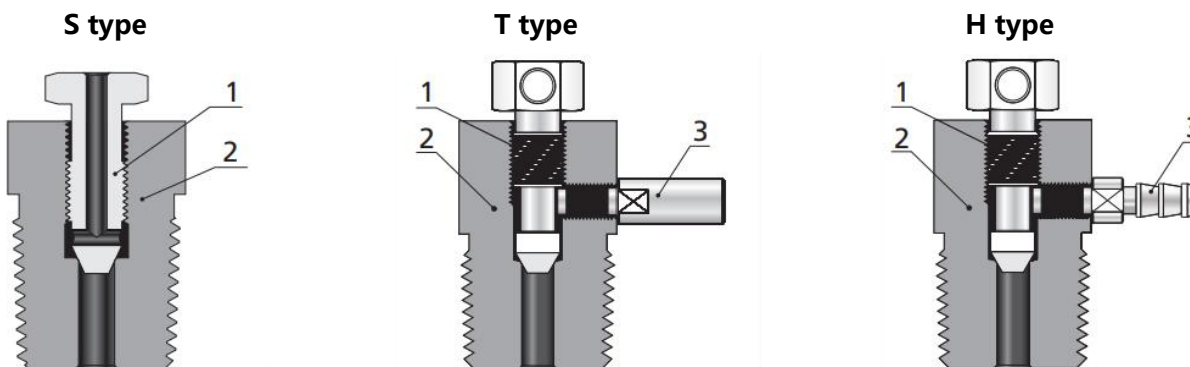

NO.	Component	Material		
		316 SS	Carbon Steel	Alloy 400
1	Stem	Hardened 316 SS/A479	Hardened 316 SS/A479	Alloy 400/B164
2	Body	316 SS/A276	1018/A108	Alloy 400/B164
3	Vent Tube	316 SS/A276	1018/A108	Alloy 400/B164

• Note: If you need other materials, please contact ROKE Sales department or local distributor.

Pressure vs. Temperature

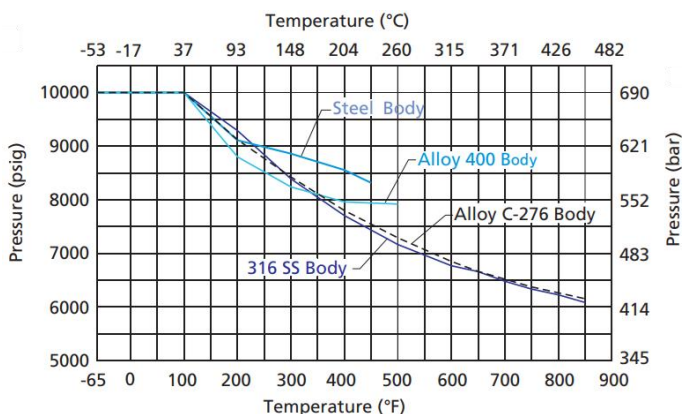

Note: Ratings based on all metal seals. Ratings limited to:

- -20°F (-28°C) min with carbon steel.
- 450°F (232°C) max with SAE end connections using fluorocarbon FKM O-rings.
- 4500 psig (310 bar) max with SAE end connections.

BDV Series Dimensions

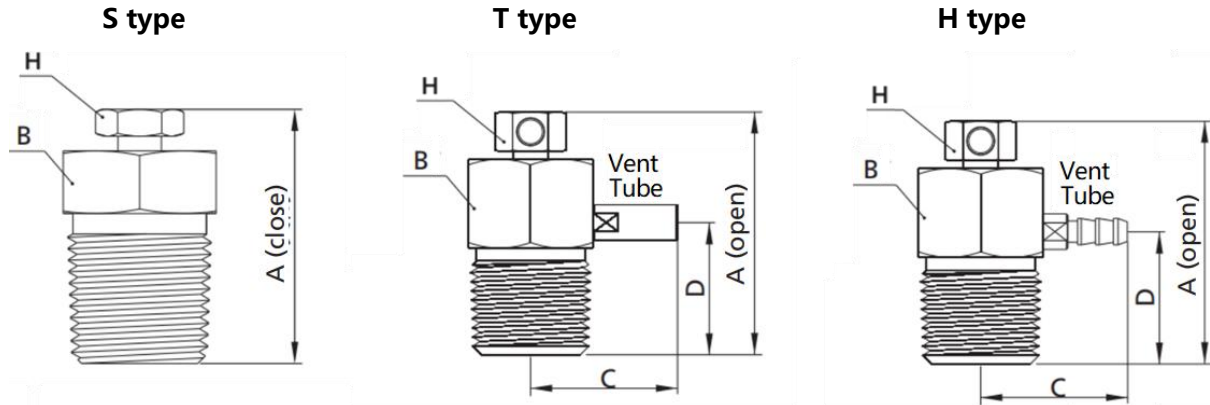

Valve Type	Basic Ordering Number	Connection Type and Size	Dimension, in.(mm)					
			A	B (hex)	C	D	H (hex)	Vent Tube
S type	-BDV-MN4-S	1/4 NPT Male	1.31 (33.4)	0.63 (15.9)			0.44 (11.1)	-
	-BDV-MN6-S	3/8 NPT Male	1.46 (37.1)	0.87 (22.2)				
	-BDV-MN8-S	1/2 NPT Male	1.46 (37.1)	0.87 (22.2)	-	-		
	-BDV-MR4-S	1/4 BSPT Male	1.31 (33.4)	0.63 (15.9)				
	-BDV-MR6-S	3/8 BSPT Male	1.46 (37.1)	0.87 (22.2)				
	-BDV-MR8-S	1/2 BSPT Male	1.46 (37.1)	0.87 (22.2)				
T type	-BDV-MN4-T	1/4 NPT Male	1.65 (41.8)	0.63 (15.9)	0.94 (24.0)	0.78 (19.7)	0.44 (11.1)	OD 1/4 (6.35)
	-BDV-MN6-T	3/8 NPT Male	1.78 (45.1)	0.87 (22.2)	1.03 (26.2)	0.91 (23.0)		
	-BDV-MN8-T	1/2 NPT Male	1.78 (45.1)	0.87 (22.2)	1.03 (26.2)	0.91 (23.0)		
	-BDV-MR4-T	1/4 BSPT Male	1.65 (41.8)	0.63 (15.9)	0.94 (24.0)	0.78 (19.7)		
	-BDV-MR6-T	3/8 BSPT Male	1.78 (45.1)	0.87 (22.2)	1.03 (26.2)	0.91 (23.0)		
	-BDV-MR8-T	1/2 BSPT Male	1.78 (45.1)	0.87 (22.2)	1.03 (26.2)	0.91 (23.0)		
H type	-BDV-MN4-H	1/4 NPT Male	1.31 (33.4)	0.63 (15.9)	0.94 (24.0)	0.78 (19.7)	0.44 (11.1)	OD 3/16 (4.8)
	-BDV-MN6-H	3/8 NPT Male	1.46 (37.1)	0.87 (22.2)	1.03 (26.2)	0.91 (23.0)		
	-BDV-MN8-H	1/2 NPT Male	1.46 (37.1)	0.87 (22.2)	1.03 (26.2)	0.91 (23.0)		
	-BDV-MR4-H	1/4 BSPT Male	1.31 (33.4)	0.63 (15.9)	0.94 (24.0)	0.78 (19.7)		
	-BDV-MR6-H	3/8 BSPT Male	1.46 (37.1)	0.87 (22.2)	1.03 (26.2)	0.91 (23.0)		
	-BDV-MR8-H	1/2 BSPT Male	1.46 (37.1)	0.87 (22.2)	1.03 (26.2)	0.91 (23.0)		

• Note: For dimensions not shown above, please contact ROKE Sales department or local distributor.

Nantong ROKE Fluid Equipment Co., Ltd.

ROKE Factory

27-28, Alpha Industrial Park, No. 333, Kaiyuan Avenue.
Hai'an City, Jiangsu Province, China
Tel :86-513-86751377
Fax :86-513-86752577

ROKE Marketing Center

B-1108, Fortune Building, No. 817, Jianghai Avenue.
Nantong City, Jiangsu Province, China
Tel: 86-513-85400443
Fax: 86-513-85400444
Web:www.chinaroke.com
E-mail:sales01@ntroke.com



ROKE
Valves ,Fittings and Tubing

www.chinaroke.com